

These are all the circuits that I've come up with to replicate the following waveforms:
Xogen, Stanley Meyer, & Henry Puharich.

Xogen Waveform

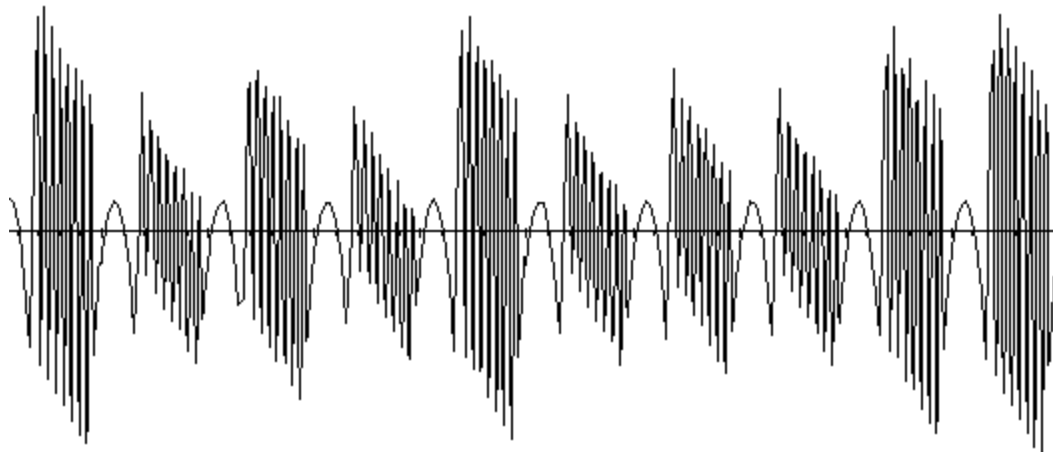

Stan Meyer Circuit

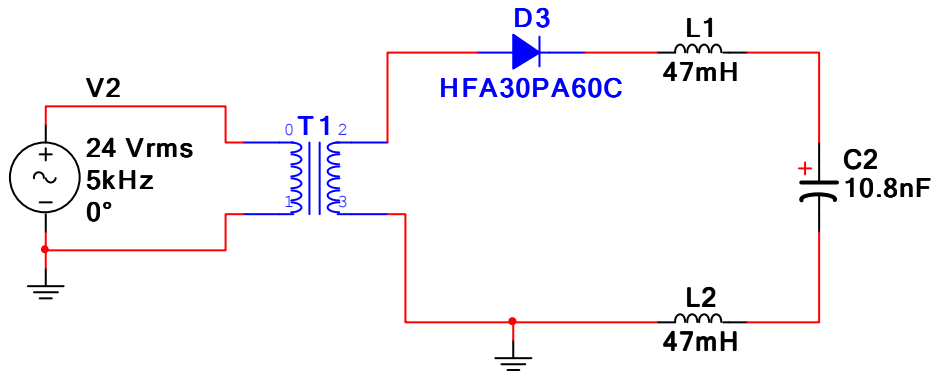
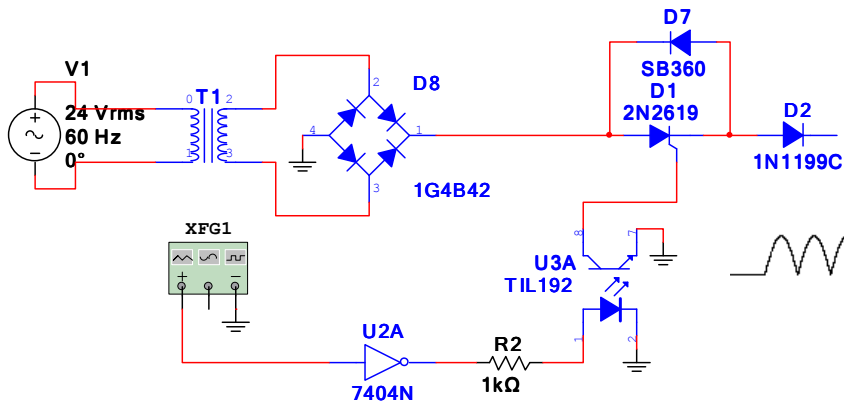
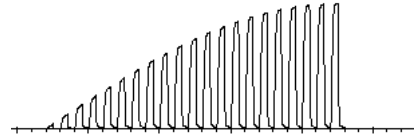
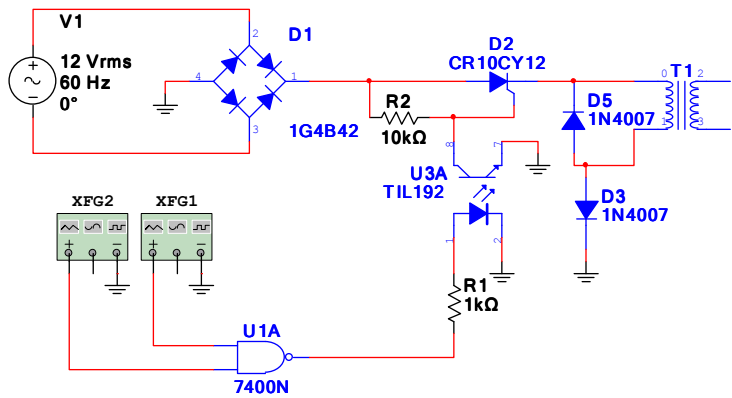

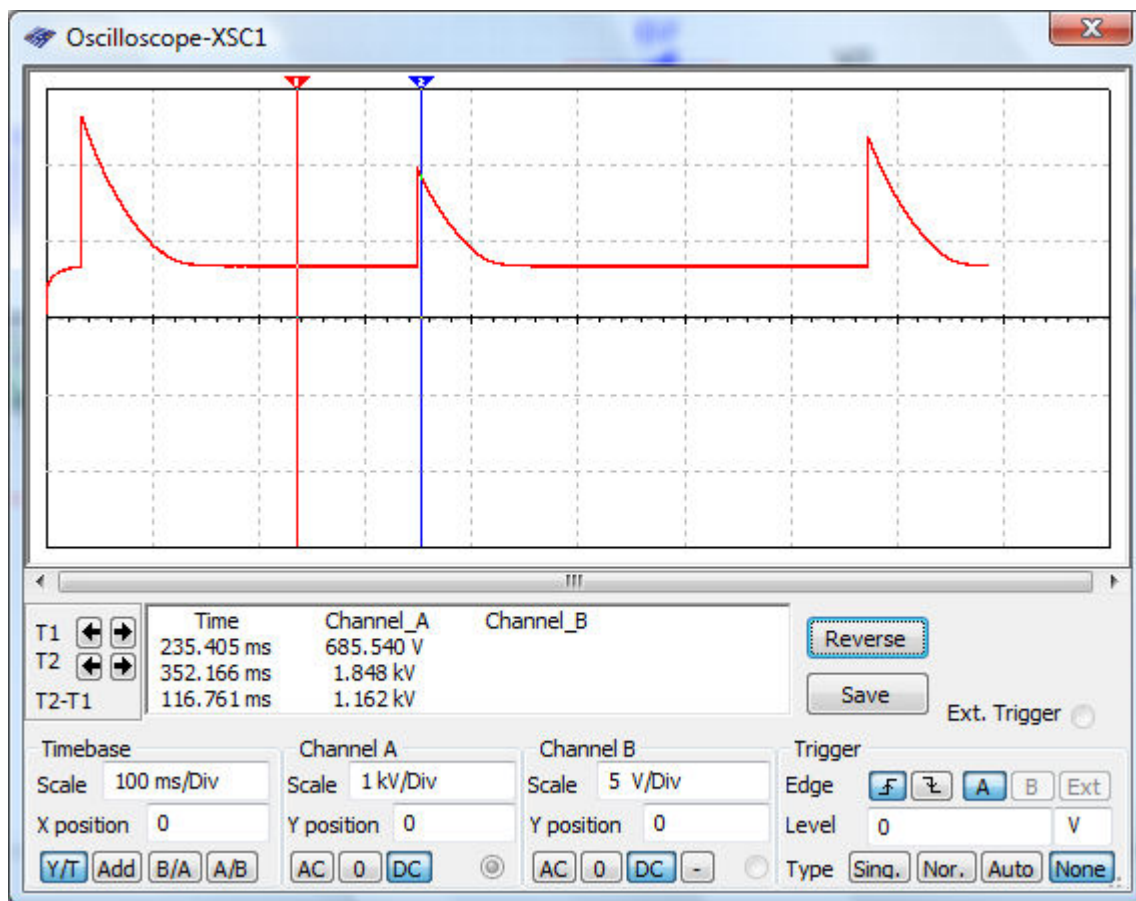
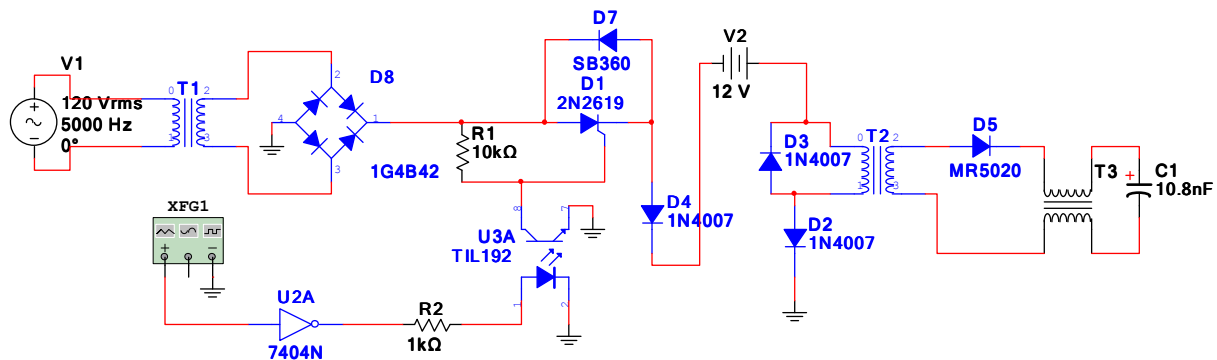

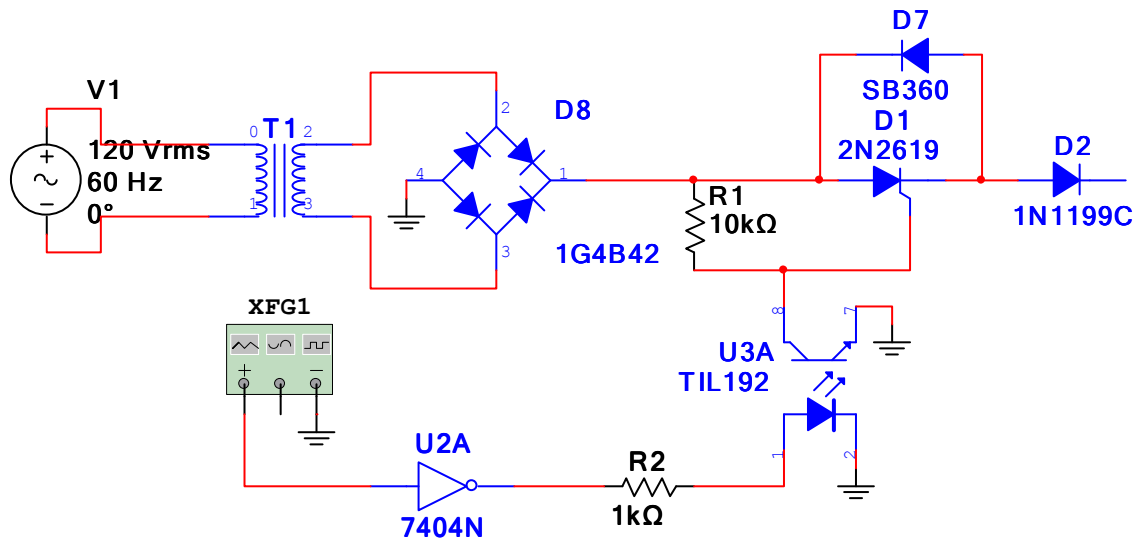

Henry Puharich Waveform

