

"Meets All Energy Needs"

873

WATER FUEL CELL

**WFC Dealership Sales
Manual**

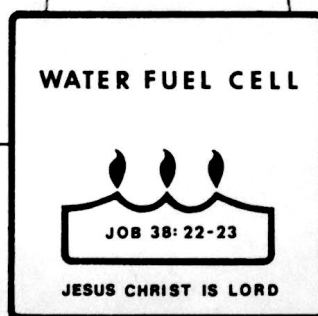

COPYRIGHT © 1986 BY STANLEY A. MEYER

**WFC Dealership Sales
Manual**

WFC Dealership Sales Manual

Preface on development

The Water Fuel Cell technical approach is based on the design philosophy that: the same engineering design criteria of one system applies to all systems regardless of size...being a retrofit energy system...using water as fuel...and doing the following:

- * Economically producing hydrogen gas on demand
- * Rendering hydrogen gas safer than natural gas
- * Transporting hydrogen gas without spark-ignition
- * Economically producing electricity from water
- * Releasing the atomic energy-yield from hydrogen

Publications available

The Birth of New Technology: WFC Technical Brief

Explaining the Hydrogen Fracturing Process on how to use water as a new fuel-source. \$25 each for U.S.; add \$4 for foreign postage. U.S. Currency Only.

WFC Dealership Sales Manual:

Explaining Water Fuel Cell business format and a general overview of WFC tech-base and related spin-off developments. \$25 each for U.S.; add \$4 for foreign postage. U.S. Currency Only.

WFC News Releases:

Yearly news update on Water Fuel Cell business and product development activities World wide. \$2 each for U.S.; add \$1 for foreign postage. U.S. Currency Only.

To attend a **WFC Dealership Seminar**, call (614) 335-2153 before 7am or after 7 pm or Fax (614) 871-8075 for scheduling information, or mail request to Water Fuel Cell, 3792 Broadway, Grove City, Ohio 43123 to obtain a Seminar authorization pass.

History In The Making

Fax Service

9:01 AM 3/29/92

**WFC DEALERSHIP REQUEST
INFORMATION**

The WFC Dealership Sales program is set up to decentralize both the installation and manufacturing of the patented Water Fuel Cell tech-base by way of the WFC Product Development and Trade Center (see WFC Prospectus Flow Chart page 4).

For WFC Dealership Sales Approval and assignment, please make all inquires via WFC fax number pertaining to listed WFC Service Areas:

Home Heating & on-site Electrical: 25K population service area: County area only; Cars: Walk-in service: Metro Area Only; Trucks: Walk-in service: Metro Area Only; Boats: Walk-in service: Marina Area Only; Manufacturing: Up to three (3) Parts Only; and Sub-Assembly Contractors.

WFC Dealership purchase price is U.S. \$50,000 each with U.S. \$5,000 deposit ...balance pay-off at the rate of 5% per sales unit profit until paid (see WFC Prospectus as per WFC Dealership Contract Agreement). U.S. Currency (U.S. Bank only) is required on Deposit payment. The "signed" and "Filled-in" WFC Dealership Contract Agreement accompanies Deposit payment. WFC Dealership purchase is subject to WFC approval.

If you have a specific application that you would consider using the WFC technology for, please submit your request via WFC fax for project and design retrofit specifications and licensing quotes. WFC Licensing of applications are subject to WFC approval.

Refer to WFC Profit Sharing Certificate Prospectus when considering purchasing a WFC Dealership or obtaining a WFC Profit Sharing Certificate

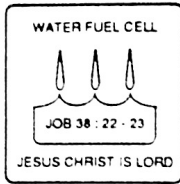

WATER FUEL CELL

WFC Dealership Sales Manual

WFC Business Plan Overview

Notice of Technology

All Rights Reserved

Printed in the United States of America. Except in the case of brief quotations embodied in critical articles or review, no part of this WFC technical brief may be reproduced in any form or by any means, or stored in a databank or retrieval system without express written permission of inventor Stanley A. Meyer. For written approval, fax (614) 871-8075 or send request to 3792 Broadway, Grove City, Ohio 43123.

All graphic illustrations were created and registered under international UCC copyright laws by Stanley A. Meyer

All publishing rights reserved by Stanley A. Meyer under international UCC copyright laws.

National Security Laws

Patent security is enforced by National security Laws of each participating country. Do "not" make, sell, or utilize a patented process and/or device without inventor written consent and approval. International patent and copyright laws mandate the same "usage" restrictions.

Information presented in this manual is not to be used for manufacturing purposes.

Foreign Grant License

The U.S. Government has allowed the WFC technology to go forward into the international market place by issuing foreign grant license No. 492680 issued July 10, 1989 and foreign grant license No. 490606 issued Nov. 15, 1989 to Stanley A. Meyer as so specified and required under the Patent Cooperation Treaty (PCT) Act. Heavy fines and imprisonment are levied on anyone who falsely claims to have participated in the development of a invention. Under the PCT Act, a Declaration of Oath must be signed, certified, and registered prior to the filing of any PCT patent application.



WATER FUEL CELL

WFC Dealership Sales Manual

Patents Granted To Date

Stanley A. Meyer

4,389,981	Hydrogen gas injector system for internal combustion engine (U.S.A.)
4,613,779	Electrical pulse generator (U.S.A.)
4,421,474	Hydrogen gas burner (U.S.A.)
1,231,872	Hydrogen injector system (CDA)
1,233,379	Hydrogen gas injector for internal combustion engine (CDA)
1,228,833	Gas electrical hydrogen generator (CDA)
1,227,094	Hydrogen/air & non-combustible gas mixing combustionsystem (CDA)
4,613,304	Gas electrical hydrogen generator (USA)
1,235,669	Controlled hydrogen gas flame (CDA)
4,275,950	Light-guide lens (USA)
1,234,774	Hydrogen generator system (USA)
3,970,070	Solar heating system (USA)
1,234,773	Resonant cavity hydrogen generator that operates with a pulse voltage electrical potential (CDA)
4,265,224	Multi-stage solar storage system (USA)
1,213,671	Electrical particle generator (CDA)
4,465,455	Start-up / shut-down for a hydrogen gas burner (USA)
4,798,661	Gas generator voltage control circuit (USA)
4,826,581	Controlled process for the production of thermal energy from gases and apparatus useful therefore (Hydrogen Fracturin Process) (PCT)
5,149,407	Process and apparatus for the production of fuel gas and the enhanced release of thermal energy from such gas (Electronic interfacing for the Hydrogen Fracturing Process) (Resonant Action) (USA) (WFC Project 423 DA)
0101761	Controlled hydrogen gas flame (EPO)
1577992	Controlled hydrogen Gas flame (JPO)
0086439	Hydrogen gas injector system for internal combustion engine (EPO)
1584224	Hydrogen Injection System (JPO)
4,936,961	Method For the production of a Fuel Gas "Electrical Polarization Process" (U.S.A.)
1,694,782	Resonant Cavity For Hydrogen Generator (JPO)
Allowed	Hydrogen Gas Fuel and Management System(WFC Hydrogen Gas Management (GMS) System : PCT/US90/06513: (WFC Project 422 DA
PCT/US91/03476	Water Fuel Injection System Burner Nozzle (WFC Project 424 DA)

Other U.S. & Foreign Patents Pending

Refer to WFC Profit Sharing Certificate Prospectus when considering purchasing a WFC Dealership or obtaining a WFC Profit Sharing Certificate

**WATER FUEL CELL
AUDIO/VISUAL
TECHNOLOGY PRESENTATION**

Bring a friend

DEER CREEK STATE PARK LODGE
20635 Water Loo Road
Mt. Sterling, Ohio 43143

- Lecture: History to Development
- Fuel Cell Demonstration
- Electrical Particle Generator
- Hydrogen Gas Processing
- Regenerative Energy Feedback Techniques
- Water Reclaim System
- Hydrogen Fracturing Process
- Dealership Sales Presentation
- Viewer Participation
- Literature Hand-out
- Free Refreshment

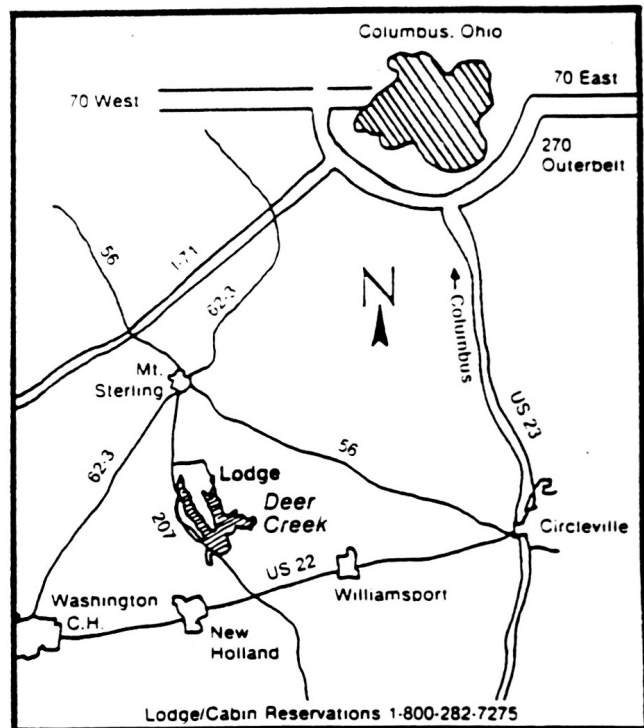

MAP LOCATOR

To attend a Dealership Seminar, please forward your request to **WATER FUEL CELL** to receive an authorization pass by return mail.

For Seminar Scheduling, Please Call:
1-614- 335-2153 before 7am or after 7pm
or fax request (614) 871-8075

Water Fuel Cell, 3792 Broadway, Grove City, Ohio 43123 Phone: 614-871-4173

WATER FUEL CELL

Technical Brief

Stanley A. Meyer
Inventor

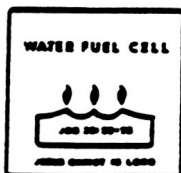

WATER FUEL CELL
INTERNATIONAL HEADQUARTERS: U.S.A.
3792 BROADWAY
GROVE CITY, OHIO 43123
614-871-4173

Notice of Technology: All Rights Reserved

Water Fuel Cell Copyright © 1986 By Stanley A. Meyer

All rights reserved. Printed in the United States of America. Except in the case of brief quotations embodied in critical articles or review, no part of this book may be reproduced in any form or by any means, or stored in a database or retrieval system without prior written permission of the Author/Inventor. For information, address Stanley A. Meyer, 3792 Broadway, Grove city, Ohio 43123.

Library of Congress Catalog Number:
ISBN:

Book History: Written in part on 06/22/85
Revised in part on 05/01/86
Revised in part on 08/04/86
Revised in part on 09/01/87

Printing Code: 85/06/001 86/05/002 86/07/225 87/09/025

Interpretation of the printing code: the leftmost double-digit number is the year of the book printing; the middle double-digit number is the month of the printing year; the right series of numbers shows the printing number of the book.

All graphic illustrations were created by Stanley A. Meyer.

U.S. & Foreign Patents Pending.

F.B.I. WARNING

PATENT SECURITY IS ENFORCED BY FEDERAL LAW: DO NOT MAKE, SELL OR UTILIZE A PATENTED PROCESS AND/OR DEVICE WITHOUT INVENTOR WRITTEN CONSENT.

INTERNATIONAL PATENT AND COPYRIGHT LAWS MANDATE THE SAME "USAGE" RESTRICTIONS.

Acknowledgments

**The Water Fuel Cell is coming in by the people
for the people.**

Dedication

MARK 16 : 15

**Go ye into all the World, and preach the gospel
to every creature.**

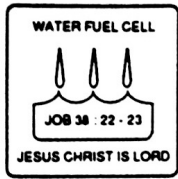

About the Author

Stanley A. Meyer

Stanley A. Meyer, a businessman and free-lance inventor, lives in Grove City, Ohio. His scientific and engineering background covers many fields of endeavors: Heart Monitors for the medical profession, the Validator System System for the banking institution, the Nivax and Actar System for the oceanography field, and the "EBED" concept for Star Wars, to mention a few. And, now, Mr. Meyer has developed the Water Fuel Cell technology to help solve the energy crisis. Many energy patents have been granted to him over the years.

Stanley A. Meyer founded and served as chairman of several high technology business and co-sponsored other business activities in the international market place.

While continuing to set up Water Fuel Cell business entity and inventing, Stanley A. Meyer has begun working on a book entitled "With the Lord, There is Purpose" describing his "faith-walk" with the Lord to fulfill end-time prophecy. He continues his speaking engagements throughout the world.

Recipient Awards of Merit:

1990 - Who's Who of American Inventors

1991 - 1992 Who's Who Of Entrepreneurs U.S.A.

1992 - Who's Who of American Inventors

1993- Who's Who of American Inventors of the Year Award

International Publications of Authorship

Raum & zeit: U.S.: Vol. 2 No. 1, 1990; Vol 3 No. 4, 1992

Raum & zeit: Europe: 9 Jahrgang Nr 44; 9 Jahrgang Nr 48; 9 Jahrgang Nr 50

Explore: U.S.: Vol 3 No. 4, 1992; Vol 4 No. 2, 1993

International Speaker of Request:

1989 SAFE International Congress for Free Energy, Einsiedeln, Switzerland

1990 International Extraordinary Science, Colorado Springs, Colorado

1991 International Global Clean Energy Congress, Geneva, Switzerland

1991 International Global Science Congress, Daytona Beach, Florida

1993 International Symposium on New Energy, Denver, Colorado

Table of Contents

1. A Preview of Water Fuel Cell Technology and This Book (6 Pages)	
Scientific Dissertation: Electrical Phenomena.....	B2
Electrical Polarization Process: Covalent Break-Up.....	B2
Explosive Force of Hydrogen.....	B3
Definition of Terms.....	B3
Water Fuel Cell Integrated Energy Grid System.....	B5
Water Fuel Cell: Composite-Expressions.....	B6
2. Pre-History to Development (12 Pages)	
In Search of Oil.....	C1
The False Hope of Nuclear Energy.....	C2
China Desires.....	C3
OPEC Conspiracy.....	C3
The Scramble to Develop Alternative Fuel Sources.....	C5
The Need for New Technology.....	C6
OPEC Dwindling Oil Reserves.....	C6
Survival or Else.....	C7
Where to Look and Why?.....	C8
The Invention.....	C10
The Economics of the Invention.....	C11
3. The Principles of Discovery (7 Pages)	
The Pursuit of Knowledge.....	D1
Electrically Charging the Water Molecule.....	D1
Electrical Polarization Process.....	D2
Covalent Break-Up of the Water Molecule.....	D5
Natural Water, The Source for Hydrogen.....	D6
4. Operational Parameters of the Invention (13 Pages)	
The Formation of Voltage Zones.....	E1
Voltage is Potential Energy.....	E2
Producing Hydrogen on Demand.....	E4
5. Mega Watt Gas Yield (18 Pages)	
Resonant Cavity: What is It?.....	F1
Resonant Action and the Phenomena.....	F1
Resonant Action Enhancement.....	F7
Atom Injected Resonant Action: The Rocket Engine.....	F13
Laser Injected Resonant Action: The Throttle Booster.....	F16
Hydrogen Gas Gun Technology: Atomic Energy Yield.....	F18

6. Fuel Cell Economics (5 Pages)

Design to Retrofit.....	G1
A Physical Process.....	G1
Hydrogen: More Powerful Than Fossil Fuels.....	G3
What's the Cost of Water?.....	G3
What's the Cost of Voltage?.....	G3
Fuel Cell Longevity.....	G4
Fuel Cell Meets The Need.....	G4
Other Fuel Cell Features.....	G4

7. Hydrogen Gas Utilization (9 Pages)

The Need to Render Hydrogen Safe.....	H1
Quenching Circuit: Anti Spark Back.....	H1
Sustained Hydrogen Flame on Demand.....	H2
Hydrogen As A Clean Burning Fuel.....	H3
Quenching Tube: Distributing Hydrogen Safely.....	H8
Fuel Cell Meets Safety Requirements.....	H8

8. Dynamic Ways to Produce Electricity (16 Pages)

Water, The Source for Electricity.....	J1
Limits Placed on Conventional Power Systems.....	J1
The Birth of New Technology: EPG Electrical Systems.....	J3
EPG: Principles of Operability.....	J3
EPG: Mechanical Drive System.....	J8
EPG: Electromagnetic Drive System.....	J8
EPG: Particle Beam Accelerators.....	J11
EPG: Attenuating Gas-Field.....	J11
EPG: Flexibility of Power Yield.....	J14
EPG: Magnetic Spin Generator.....	J15
EPG: Operational Parameters.....	J15
Fuel Cell Linked to EPG Systems.....	J17

9. Spin-Off Technology (17 Pages)

Transmitting Hydrogen through Conventional Gas Lines.....	K1
Steam Resonator.....	K3
High Frequency Pulsing Generator.....	K5
Electrical Pulse Generator.....	K5
Light Guide Lens Assembly.....	K8
Gas-Driven Electrical Generator.....	K8
Internal Combustion Generator.....	K11
Thermal Pump Electrical Generator.....	K11
Electrical Polarization Generator.....	K11
Hydrogen Gas Reclaim System: Water Purification.....	K16
The Water Fuel Cell Technology Answers the Question.....	K17

1

A Preview of Water Fuel Cell Technology and This Book

Water Fuel Cell Technical Base (graphically illustrated in Figure A) is a sophisticated integration of many energy systems integrated together to form a versatile energy package...utilizing sun, air and water to produce electrical energy, gas, mechanical, and/or heat energy without the aid of additive chemicals or fossil fuels. As shown in Figure A, the flow diagram is subdivided into four major areas: electrical power generators, hydrogen gas generators and processors, regenerative energy feedback systems, and reclaim and recycling systems. A solar energy processing system (Figure 35) as well as steam resonator system (Figure 32) can be added or retrofitted to this energy grid system.

Each system application offers a full set of features and several applications can be used at the same time. You can easily move from one energy system to another for a predetermined energy need. Basically, the system grid is arranged in such a way as to produce electrical energy from natural water. Using that electrical energy to produce hydrogen energy from water for utilization. Since sun, water and air determine system economics, the hydrogen age can now replace the fossil fuel era.

The Water Fuel Cell of figure B is the composite expression of Flow Diagram Figure A.

ELECTRICAL POLARIZATION PROCESS: COVALENT BREAK-UP

Once the atoms of the water molecule become electrically charged, the covalent bonding (sharing electrons between atoms) become non-existent since the electrically charged fields surrounding the atoms disrupt the electron movement...causing the water molecule to split into its component parts...liberating the electrically charged hydrogen and oxygen atoms for utilization (see Figures 2 and 3).

Basically, the positive electrically charged hydrogen atoms will momentarily attract the negative charged electrons, while at the same time, the negative electrically charged oxygen atom momentarily repels said moving electrons...preventing electron sharing between the atoms...stabilizing the atom energy levels to stable state...liberating the atoms from the molecule.

EXPLOSIVE FORCE OF HYDROGEN vs JOULES OF ENERGY

The scientific expression "gtnt" refers to the explosive force per atomic weight of hydrogen during detonation under pressure. Joules of energy (watt-hour) should not be used in place of "gtnt" (explosive force of detonation) when equating the power yield of hydrogen undergoing atomic breakdown.

DEFINITION OF TERMS

The law of physics is defined as duplicating a given function continuously without change.

The ensuing chapters and pages briefly describe the basic fundamental principles of system operability and purpose of development, see Chart C as to Flow Diagram A and Fuel Cell B. The wording and phraseology used in this technical brief are directed to the general public to communicate a simple but profound answer to the energy crisis.

SCIENTIFIC DIS SERTATION: ELECTRICAL PHENOMENA

Physics is a composite of many fields of studies...of which the electrical phenomenon is one of them. Voltage is electrical pressure or force within an electrical system called potential. The words "voltage potential" herein used describe the purpose of performing work whenever different energy levels exist within the electrical system: unlike charges attract while like charges repel.

The voltage potential phenomenon is simply illustrated in the cyclotron where the electrically charged particles are accelerated by an alternating electrical field. The brightness control on your T.V. set or computer monitor performs a similar function.

In like manner, the Water Fuel Cell utilizes the voltage potential phenomenon by setting up dual voltage zones to attract opposite electrically charged atoms: the positive electrical charged hydrogen atoms being attracted to the negative electrical charged voltage zone while the negative electrical charged oxygen atoms are being attracted to the positive electrical charged voltage zone. This process is non-reversible since like charges repel each other.

Therefore,

a proven function becomes a Law of Definition.

Example:

Law of Motion, Law of Inductance, and so on.

Consequently,

the Law of Definition as to proven function is herein used throughout this technical brief as merit of expression.

The Law of Change:

A Law of Physics establishes a proven function based on preset conditions...change any one of the conditions and the law no longer applies.

Therefore, the word groupings "voltage potential," "Law of Definition," the "Law of Change," "Electrical Polarization Process" and "gtnt" should not be taken out of context when reading this technical brief.

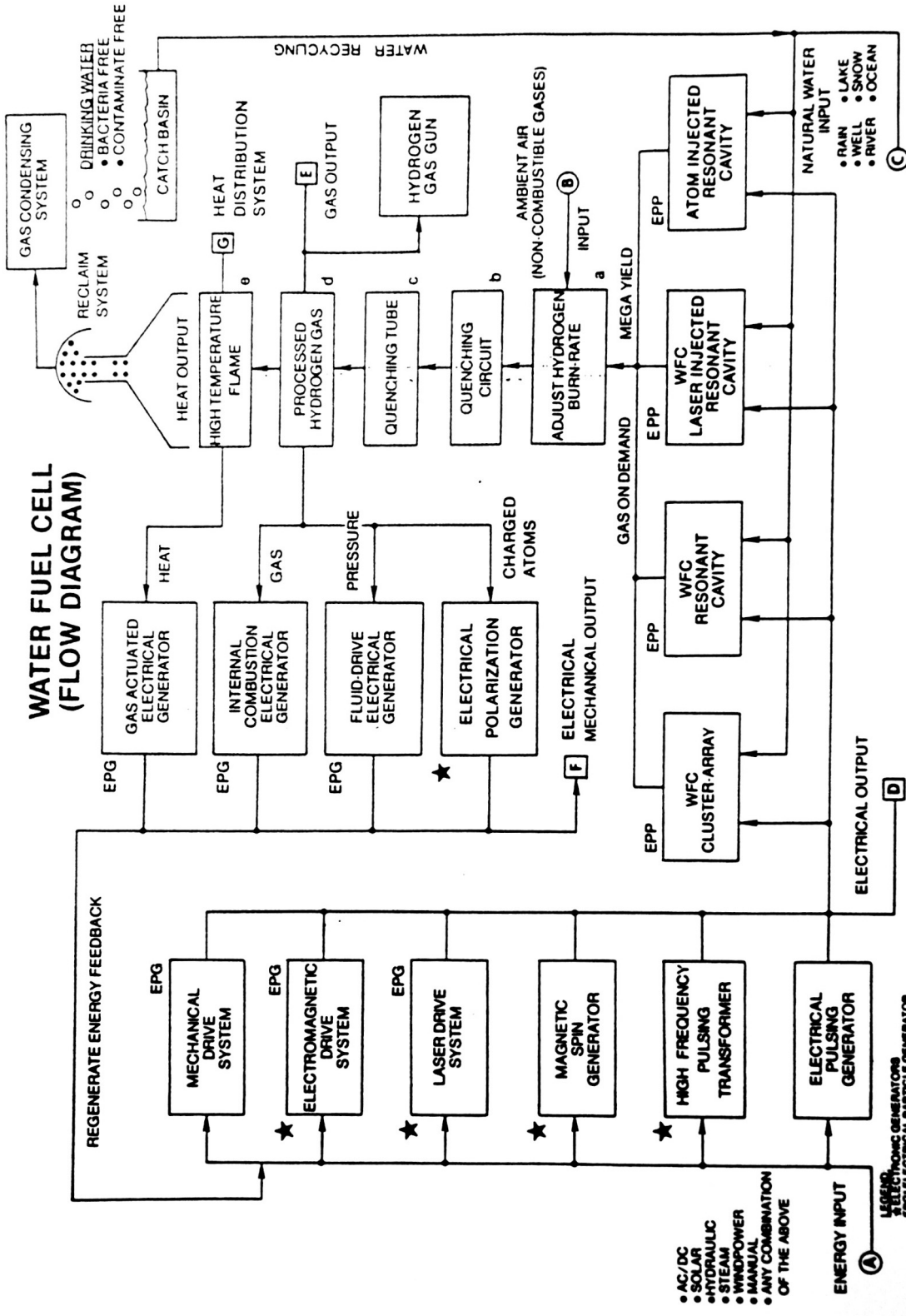

FIG. A: INTEGRATED ENERGY SYSTEMS (MODULAR RETROFIT)
 COPYRIGHT © 1998 BY STANLEY A. MEYER

- AC/DC
- SOLAR
- HYDRAULIC
- STEAM
- WINDPOWER
- MANUAL
- ANY COMBINATION OF THE ABOVE

LEGEND:
 # ELECTRONIC GENERATORS
 * ELECTRICALLY DRIVEN GENERATOR
 EPP ELECTRIC POLARIZATION PROCESS
 # ANTI-SPARK BACK
 # ADJUST HYDROGEN GAS TO CO-EQUAL FOSSIL FUELS
 # DISTRIBUTE HYDROGEN GAS WITHOUT SPARK IGNITION
 # SUSTAINED REGARDLESS OF GAS RATE
 # ELECTRICALLY CHARGING
 # ATOMS PRIOR TO GAS-IGNITION

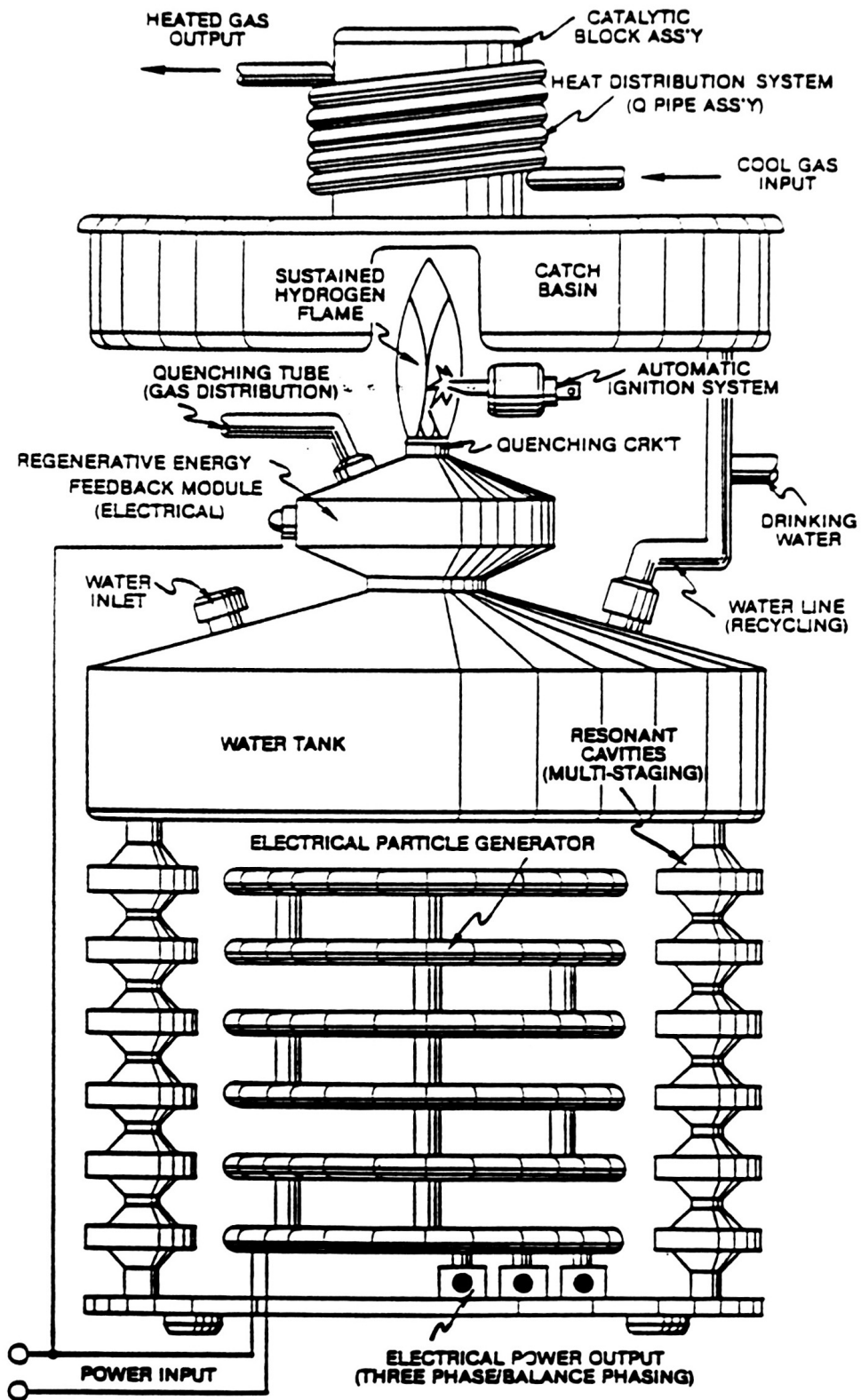

FIG B: WATER FUEL CELL

COPYRIGHT © 1983 BY STANLEY A. MEYER

WATER FUEL CELL Research and Development Format Chart C

RESEARCH PROJECT	PURPOSE OF DEVELOPMENT
FUEL CELL TECHNOLOGY: <ul style="list-style-type: none"> • Electrical Polarization Process (EPP) • Voltage Intensifier Circuit • Cluster-Array • Resonant-Cavity • Laser Injected Resonant Cavity • Atom Injected Resonant Cavity • Hydrogen Fracturing Process 	Producing hydrogen gas economically from water by way of voltage stimulation. Controls hydrogen gas production on demand. Light Manufacturing. Home/Transportation. Medium Industry. Heavy Industry. Controlled energy-yield from water atoms (Aircraft/Rocket Engines/Space Stations).
PROCESSED HYDROGEN GAS: <ul style="list-style-type: none"> • Rendering Hydrogen Gas Safe • Quenching Circuit • Quenching Tube • Hydrogen Ignition • Start up/Shut down Electronic Circuit • Hydrogen Pipe-Line Storage • Hydrogen Gas Reclaim 	Adjust hydrogen gas burn-rate to co-equal natural gas. Anti-Spack Back. Distribute hydrogen gas without spark-ignition. Sustain and maintain hydrogen flame regardless of gas-rate. Automatically re-ignites hydrogen gas after flame-out. Transporting hydrogen gas through existing gas-lines safely. Recycling water for hydrogen reuse and producing drinking water free of bacteria and contaminates.
ELECTRICAL POWER GENERATION: <ul style="list-style-type: none"> • Electrical Particle Generator (EPG) • EPG Mechanical Drive System • EPG Electro Magnetic Drive System • EPG Laser Drive System • Magnetic Spin Generator • Spiral Transformer Configuration • Electrical Pulsing Generator 	Using a magnetized gas or slurry to produce electrical energy without any air-gap. To propel said magnetized gas/slurry by way of mechanical displacement. To propel said magnetized gas/slurry by way of electromagnetic deflection. To propel said magnetized gas/slurry inside an light-guide tube by way of photon or particle injection. Re-orientate dyne-axis of said magnetized gas/slurry by way of variable pulse voltage. Pass electrical energy at high pulse voltage frequencies. Electromagnetic Amplifier that produces a variable pulse voltage frequency.
ELECTRICAL FEEDBACK NETWORK: <ul style="list-style-type: none"> • Gas Activated Electrical Generator • Internal Combustion Electrical Generator • Fluid-Drive Electrical Generator • Electrical Polarization Generator 	Using a thermal pump to move said magnetized gas/slurry to produce electricity. Using internal combustion engine power by said processed hydrogen gas to move said magnetized gas/slurry to produce electricity. Using said hydrogen gas pressure to move said magnetized gas/slurry to produce electricity. Using electrical charged gas to produce electrical energy.
OTHERS: <ul style="list-style-type: none"> • Steam Resonator • Light-Guide Lens Assembly 	Producing superheated steam by way of polar-voltage stimulation. Collect, Redirect, Transfer, and Focuses solar energy without any moving parts.

The above said research and development projects now makes the Water Fuel Cell Technology an universal energy system, having retrofit and mass production capabilities. The Water Fuel Cell Technology simply uses water to produce both gas and electrical energy on demand.

PHASE I and II

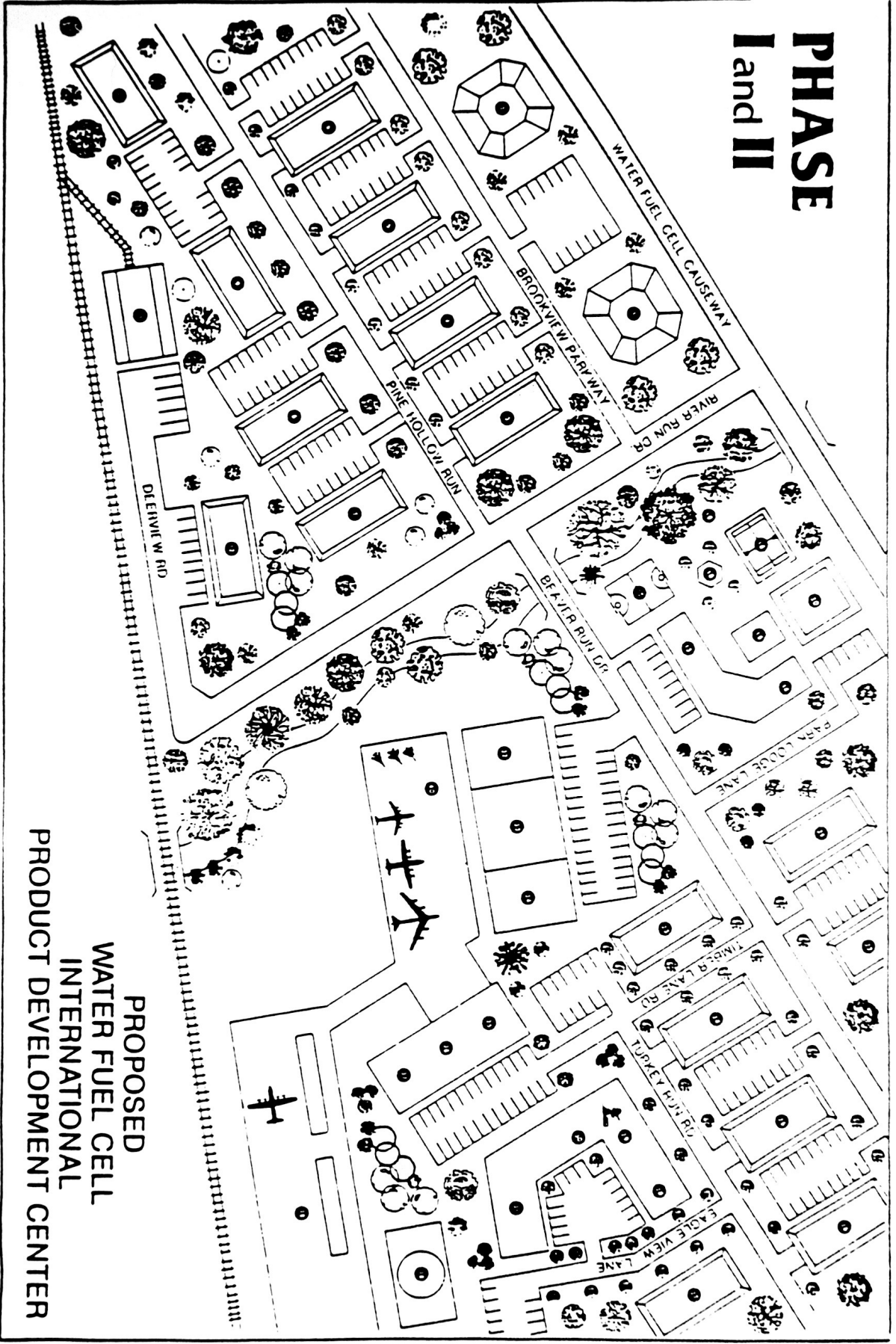

COPYRIGHT © 1987 STANLEY A MEYER

PROPOSED
WATER FUEL CELL
INTERNATIONAL
PRODUCT DEVELOPMENT CENTER

Proposed
WATER FUEL CELL
International
Product Development Center

Executive Directors

- 1) VIP Area
- 2) Central Operating

Engineering Design Facilities

- 3) Electronic System Controls
- 4) Home Heating
- 5) Home Electrical
- 6) Water Purification Systems
- 7) Marine Applications
- 8) Auto
- 9) Trucks
- 10) Grain Drying
- 21) Space Deployment
- 22) Research & Development Lab
- 23) Advance System Design
- 24) Light Industrial
- 25) Medium Industrial
- 26) Heavy Industrial
- 27) Rocket Propulsion design Group
- 28) Material Assessment Group
- 35) Aviation Design Group
- 36) Naval System Design Group
- 37) Quality Control Assessment Group

Engineering Support Facilities

- 11) System Packing Specialists
- 12) Machine/Metal Shop
- 32) Testing Complex (A)
- 33) Testing Complex (B)
- 34) Testing Complex (C)

Recreational Facilities

- 13) Sports & Game Center
- 14) Cafeteria & Coffee Shop
- 15) Swimming Pool
- 16) Health Bar
- 17) Basketball Courts
- 18) Tennis Courts
- 19) Park Area
- 20) Cultural Arts & Entertainment Center

Data Processing Facilities

- 29) Telecommunication Center
- 30) Video Documentation
- 31) Technical Writing

Transportation Facilities

- 11) Railroad
- 39) Airport
- 38) Air Traffic Control Tower
- 40) Heliport
- 41) Trucking

2

Pre-History To Development

During the middle to late 1970's, the industrialized nations of the world came to the bleak realization they no longer controlled their own capacity to produce goods and services. This alarming condition developed because the majority of the world's remaining energy reserves were no longer in their control.

IN SEARCH OF OIL

The Western World had enjoyed several centuries of unchecked industrialization, and showed no signs of slowing in the early 1970's. At the beginning of this industrialization period, wood was the primary source of energy. When wood became scarce and inefficient, coal became an abundant source of energy to further spur economic expansion. Coal, however, gave way to an even more efficient, cleaner, and seemingly more abundant fuel source -- oil.

Countries such as the United States were still expanding their industrial bases at such a rate that energy reserves equivalent to an Alaskan oil field needed to be discovered every 90 days so the existing fossil fuel demand could be met. However, during the middle to late 1960's, the United States also discovered that the oil pressure in its productive fields began falling dramatically. Oil fields that once

supplied vast amounts of energy to the greatest industrialized countries of the world were simply beginning to produce less and less, at a time when energy needs were growing daily.

In 1965, the United States imported about five percent of its oil. By 1975, the U.S. was importing more than 40 percent of the oil it needed to maintain its industrial base. This was necessary because oil pressure in productive fields was dwindling, and it was not economically feasible to attempt secondary recovery processes to revitalize these fields.

The U.S. and other industrialized countries, such as Japan, Great Britain and West Germany, could no longer count on their own energy production to keep their economies healthy, but without energy, their economies would fail--continued industrial growth would be simply impossible. Although the industrialized Western countries imported oil from Middle East nations to keep their economies afloat, they were looking forward to the day they could become energy independent through the use of the next energy source--nuclear fission.

THE FALSE HOPE OF NUCLEAR ENERGY

Just as coal replaced wood and oil replaced coal as the primary fossil fuel, the industrialized countries were looking for the replacement of oil by nuclear energy. Although there were technical problems with the use of nuclear power plants, their use became popular. There was hope that the problems with nuclear plants would be solved as they were used. For a time, the future of nuclear power plants looked promising, but then it became clear that nuclear

engineers could not solve the major problem of "the hourglass effect." Basically, the nuclear energy production process inherently caused the power plants themselves to deteriorate. The constant handling of uranium, contaminated water, steam and air quickly alters the physical properties of welds in pipes, valves and other structures within the nuclear power plants. Power plants that cost billions of dollars to build had working lives of a little more than two decades. Many of the first nuclear plants built are now being taken off line because they have absorbed as much contamination as possible without suddenly falling apart during use--causing a disastrous accident.

CHINA DESIRES

Interestingly, at the time the West began importing oil and discovering nuclear plants were not the savior they had anticipated, China began opening its doors to Western technology. What the West had accomplished in several hundred years would take China only a matter of decades to duplicate. China, with a quarter of the world's population, was eager to obtain the same goods and services available to the rest of the industrialized nations. To do this, it was obvious they had to compete for the same oil that was already in great demand by the West; thereby perpetuating the world-wide energy gap, as shown in Figure 1.

OPEC CONSPIRACY

Obviously, countries such as the United States did not enjoy relying upon the Organization of Petroleum Exporting Countries (OPEC) for energy. Figuratively and realistically, the Middle East oil-

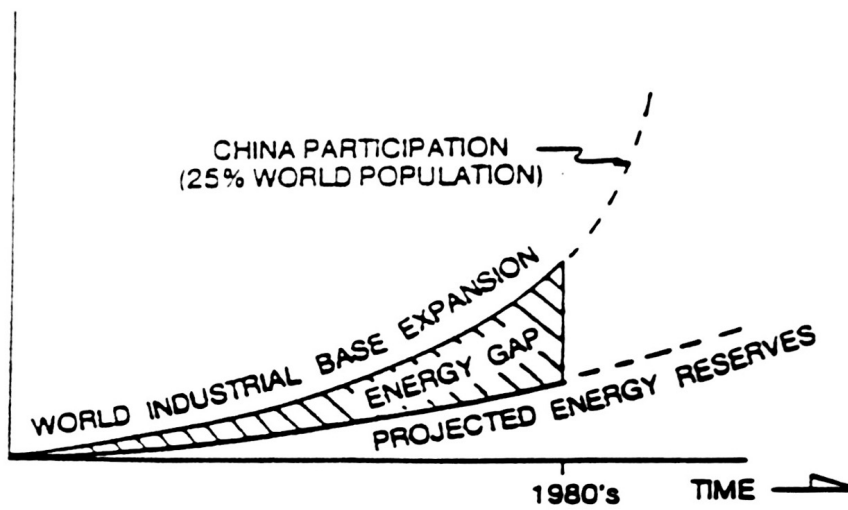

FIG. 1: ENERGY GAP

Copyright © 1980 by Stanley A. Meyer

producing countries had the Western economies over a barrel. A sudden reduction of oil flow from OPEC to the West would create havoc with the world's industrial base. What industrial leaders feared most became a reality in the oil crisis of 1975.

The nations of OPEC realized their desert oil fields were crucial to the industrial well-being of the rest of the world. Knowing they controlled a popular commodity, and adhering to economic laws of supply and demand, the OPEC nations reduced the amount of oil they were exporting and increased its price. Because the supply of oil was reduced, competition increased for the oil available on the market. This further caused the cost of OPEC oil to spiral upward.

The industrialized countries were paying inflated prices for oil to keep their economies stable, if not in expansion. But the OPEC oil became so costly, the goods and services produced through use of the oil also became costly--to the point that product consumption decreased, industry production decreased, people became unemployed, and economies began to falter.

THE SCRAMBLE TO DEVELOP ALTERNATIVE FUEL SOURCES

When economic hardship became a reality due to the oil crisis, Western government began to scramble to develop alternate fuel sources to supplement dwindling oil reserves and an unrealistic nuclear energy promise. The administrations of Presidents Gerald Ford and Jimmy Carter declared energy independence as one of their paramount goals. Work was intensified to find a viable energy source through exotic solar, wind and chemical devices.

THE NEED FOR NEW TECHNOLOGY

Industrialized countries were caught in a dilemma. While the Western industrial base was becoming more and more dependent upon energy supplies that could evaporate at any time, work was being done to develop the technology to make the exotic energy sources viable on a large scale. Unfortunately, the West became more dependent upon foreign oil daily and the exotic forms of energy production did not become economically feasible.

Solar, wind and chemical devices usually require as much, or even greater amounts of energy to use than the amount of energy produced through their use. These devices are sometimes so costly to construct (because of exotic materials needed or space required -- i.e., solar panels), that even the use of high-priced oil is more cost effective. Technology relating to solar and wind energy, for example, are limited to small geographical areas. Even for persons living in desert areas, the construction of efficient solar panels to energize homes would require great space and great cost. The problem would be even more exaggerated for industrial applications.

OPEC DWINDLING OIL RESERVES

Complicating the energy dilemma even further, many of the indicators that became apparent prior to the reduction of pressure in U.S. oil fields seem to be taking place in the oil fields of the OPEC nations. Even if OPEC keeps oil sales to the West steady and the price of the oil low, the existence of their crude reserves may be dwindling. Without the abundance of OPEC oil, economies that are momentarily

healthy would begin to suffer similar problems of the 1970's, except this time it would be more disasterous.

Even so, the industrialized world depends on foreign energy to maintain its economies. And energy independence seems hopeless through nuclear or exotic energy production because of application problems and cost. Returning to coal and wood for energy would be costly and inefficient, would perpetuate the pollution problem and even be difficult because of availability of the materials. Also, industries are geared for the use of oil--retooling and returning to the use of coal and wood would require years or even decades to accomplish.

SURVIVAL OR ELSE

It is obvious the world needs an answer immediately to the energy problem. Industry, governments, and the average person do not have decades to wait for energy answers--especially if oil supplies from the Middle East were to be suddenly halted. If supplies were halted, there would be no time to revert back to outdated fuels or finalize technology for new fuels. Without fuel, industries would close; farmers could not plant nor harvest; economies would collapse; masses of people would starve.

Naturally, before that calamity, governments would intervene to ensure their oil supplies were maintained. The use of military force in the Middle East would be a viable alternative to economic collapse and mass starvation. Should a military confrontation occur, however, refineries, oil supply line equipment and hardware would be destroyed. Refineries, supply lines, pumping stations, etc., would take years to

replace. Industrialized countries would still be without their lifeblood in the interim.

WHERE TO LOOK AND WHY?

It is apparent that if the world community desires to maintain or improve upon its current lifestyle and avoid eminent military confrontations, a new, free and abundant energy-fuel source must be developed soon. Wood, coal, natural gas, oil, solar, wind, hydroelectric, and nuclear energy sources have limited applications, limited supply, high cost, and sometimes create undesirable by-products. A new energy source must be discovered that is readily available, economical to use, and creates no detriment to the environment. Because there is no time to waste on extensive research, the new energy source must also be flexible and adaptable to all forms of industry, residential and transportation applications.

Scientists everywhere agree that the only plausible solution to this enormous problem would be the use of one of the world's most abundant, most powerful elements on the face of the earth. That is hydrogen. After all, the earth's surface is 75 percent water, of which two-thirds is hydrogen. If only this hydrogen could be harnessed effectively, the world's energy problem would be solved almost instantly.

Although researchers hoped nuclear energy would be the answer to the planet's energy needs, the idea of using hydrogen from natural water has even a greater dream. The thought of pouring ordinary water into a mechanical device for energy is quite inviting. After all, how

much does rain, snow, river or lake water cost. What ill effects could water have on the environment? The by-product of hydrogen and oxygen during the combustion process is water vapor.

Hydrogen has been used as a fuel source before, but with limited success. Extracting hydrogen from water for use as a fuel has proven even less fruitful. There are four major technical questions that must be answered before natural water and the hydrogen it contains may be used as a fuel source. These questions are: how to produce the hydrogen (extract from water) economically; how to control the rate of the hydrogen production; how to adjust the burn rate of the hydrogen to co-equal that of fossil fuels; and how to transport the hydrogen gas without spark ignition.

Although the hydrogen has been used as a fuel, primarily in laboratory experiments and models, it has always taken a great deal of energy just to produce hydrogen or extract it from water. As in other forms of experimental energy sources, hydrogen has been too costly to use. Aside from cost, just maintaining production of hydrogen has been found to be difficult. Erratic production characteristics further limit dependability. Also, hydrogen has been found to be extremely volatile (two and a half times more powerful than gasoline), even in a laboratory setting. Finally, no one has successfully demonstrated how hydrogen can be transported safely. Even if the previous problems were solved, hydrogen's use would still be limited because transmission of the gas would be impossible.

THE INVENTION

One man, with a relentless desire to solve the world's energy problem, has now answered the questions that before prevented man from using hydrogen on a wide scale. Stanley A. Meyer from Grove City Ohio, has been working since 1975, since the near disasterous oil crisis, to make the United States and other industrialized nations free from dependency on OPEC oil. He did this by inventing and perfecting the "WATER FUEL CELL."

The Water Fuel Cell uses natural water (such as tap, lake, river, snow, rain, distilled, reservoir, pond, or even ocean water) and produces hydrogen efficiently (with hardly any energy input) for use as fuel. What's more, Meyer not only can produce the gas cheaply, he has also discovered how to control the rate of the gas production, adjust the burn rate of the hydrogen to co-equal the burn rate of fossil fuels and transport the gas safely.

Because of these landmark discoveries, the gas may be used in any application. The hydrogen gas may be used in industry, office buildings, the home, the farm, in automobiles, in airplanes, and in boats. In short, wherever energy is needed, Meyer has the capability to extract hydrogen from ordinary, natural water and use it as fuel.

Since he has the four major questions answered with his Water Fuel Cell, the system can be easily retrofitted to any existing energy-consuming device. There is no need for re-tooling oil-using industries for exotic fuel usage. Automobiles or their engines will require only minor adjustments (hardly any to the engine) for coupling with the water fuel cell. The same can be said for homes and other buildings

and their natural gas and electric furnaces. And Meyer has found a way to transport the hydrogen gas even more safely than natural gas.

When Meyer began working on the fuel cell a decade ago, his engineering, industrial, and business background provided him with the realization that highly technical developments rarely came through governments or multi-national corporations. It is historically proven that individuals or small groups of individuals see a need and are able to fill the need with their own creative thinking. United States and foreign patent law substantiates this premise by awarding the patents only to individuals.

THE ECONOMICS OF THE INVENTION

Realizing this, it was also obvious that economic law would dictate his success. The person devising the cheapest solution to the energy problem would "win out." So, in order to be successful in bringing his new and revolutionary Water Fuel Cell into the market place without losing control of the discovery to outside economic and hostile forces, several conditions had to be met.

First, there could be no prior patents pertaining to a water fuel cell device. If someone had prior patents, his attempts to devise a system could be lawfully halted. Secondly, the system had to be made of very readily available materials, again stressing that there is not time to develop exotic or elaborate systems. Use of "off the shelf" materials also prevents unscrupulous suppliers from effectively stalling the construction of the fuel cell. Thirdly, the invention must be simple enough for construction in a garage or backyard. This

again prevents control by elaborate manufacturing processes. Fourthly, a person must have the capability to build a system in one day. This would allow the country to mobilize extremely fast in the face of another energy crisis. Finally, the same engineering design criteria must apply to all of the systems, regardless of the power output of each system. The same principles had to apply to the laboratory models up to the megawatt facilities for industrial applications.

3

The Principles of Discovery

In order to conform with the development criteria, it is clear that hydrogen gas must be produced economically, without the use of exotic materials or complicated processes. The question loomed before Stan Meyer of how to easily separate the hydrogen from the oxygen in the water molecule. If the atoms of the water molecule could easily be disassociated, hydrogen would be a cheap and abundant fuel source.

THE PURSUIT OF KNOWLEDGE

Meyer dealt with the prospect of how to capitalize upon the natural potential held by the hydrogen and oxygen atoms which keep the water molecule bound together. He discovered the simple yet profound principle, ELECTRICAL POLARIZATION OF THE WATER MOLECULE.

ELECTRICALLY CHARGING THE WATER MOLECULE

It is already known that the hydrogen and oxygen atoms by themselves may take on electrical charges. But until now, no one discovered that by simultaneously exposing the water molecule to one positively charged and one negatively charged electrical voltage zone, the unlike hydrogen and oxygen atoms assume opposing electrical characteristics, equal in magnitude and potential, thereby stabilizing the electrical polarity of the water molecule into existence. In the

water molecule, the two hydrogen atoms take on a positive (+) electrical charge and the one oxygen atom takes on a negative (-) electrical charge, thereby satisfying the two basic laws of physics...for every action there is an equal and opposite reaction, and that all things must reach a stable state, as so illustrated in Figure 2.

Although the molecule is stabilized in electrical polarity by the simultaneous application of the two oppositely charged voltage zones, the bond between its atoms is greatly weakened in this process. The positively charged hydrogen atoms are attracted to the negatively charged voltage zone, and the negatively charged oxygen atoms are attracted to the positively charged voltage zone...satisfying the opposite polarity attraction law of physics as shown in Figure 3.

ELECTRICAL POLARIZATION PROCESS

Simply, the electrical polarization of the water molecule is basically a four step process. First, oppositely charged electrical voltage zones are simultaneously introduced to either side of the water molecule. Secondly, the water molecule becomes electrically polarized (electrically charged). Thirdly, this electrical polarization of the hydrogen and oxygen atoms greatly weakens the stability of the water molecule. And, finally, because the voltage zones are still present with their opposite electrical attractions, the water molecule is split into its component parts. The hydrogen and oxygen atoms separate, with the hydrogen being attracted to the negative electrical voltage zone,

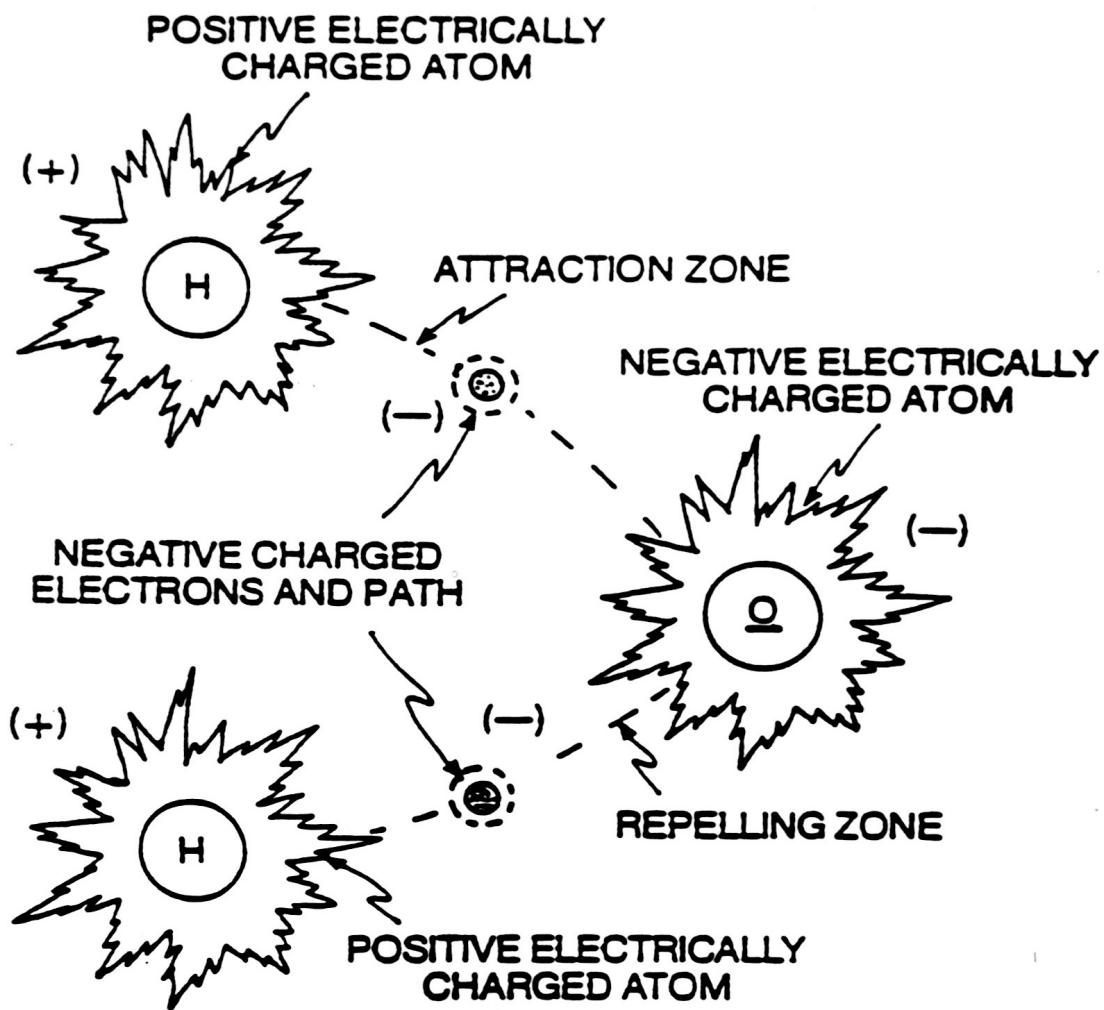

FIG 2: ELECTRICAL POLARIZATION OF THE WATER MOLECULE

COPYRIGHT © 1981 BY STANLEY A. MEYER

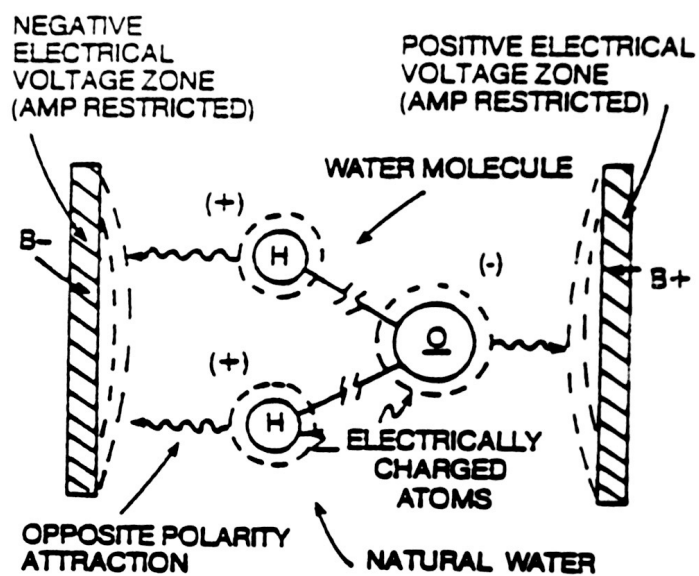

FIG 3: UTILIZING VOLTAGE POTENTIAL TO SPLIT THE WATER MOLECULE

Copyright © 1981 by Stanley A. Meyer

while the oxygen is attracted to the positive electrical voltage zone...all simultaneously.

COVALENT BREAK-UP OF THE WATER MOLECULE

In scientific terms, once the electrical polarization process occurs, the covalent bonding or sharing of electrons between atoms of the water molecule ceases to exist since the positive electrically charged hydrogen atoms attract the free floating negative charged electrons; while, at the same time, the negative electrically charged oxygen atom repels the moving electron...thereby stabilizing the energy level of the atoms...separating the water molecule into its component parts...releasing energy in the form of hydrogen gas and oxygen gas, as illustrated in Figure 3. The opposite polarity attraction that now exists between the liberated electrically charged atoms and the stationary electrical voltage zones further aids the splitting process. The repetitive pulse voltage frequency potential, or reforming voltage zones, continue the electrical polarization process.

What is so dramatic about disassociation of the atoms in the water molecule is the ease at which the task is done. Because the bond between the hydrogen and oxygen is already greatly weakened by the electrical polarization of the water molecule, very little energy in the form of applied voltage is needed to actually separate the hydrogen and oxygen atoms. The hydrogen and oxygen atoms that make up the water molecule are already seeking to move in opposite directions because of their respective attractions to the opposite electrical voltage zones. A minute amount of voltage, a potential energy without

amp consumption, gives the atoms the impetus to break away from one another in a strictly physical process. Hydrogen and oxygen gases are released in great amounts with little energy being consumed and without chemical interaction. Once the splitting of the molecule occurs, the liberated hydrogen and oxygen atoms will not recombine in the polarization process. Therefore, the gas can be utilized for energy consumption.

NATURAL WATER, THE SOURCE FOR HYDROGEN

Under actual lab certification testing, it is shown that by utilizing pulse voltage frequency potential, splitting of the water molecule occurs in all natural water, even distilled water, as shown in Figure 4.

RECYCLABLE ENERGY SOURCE
(NON-POLLUTING)

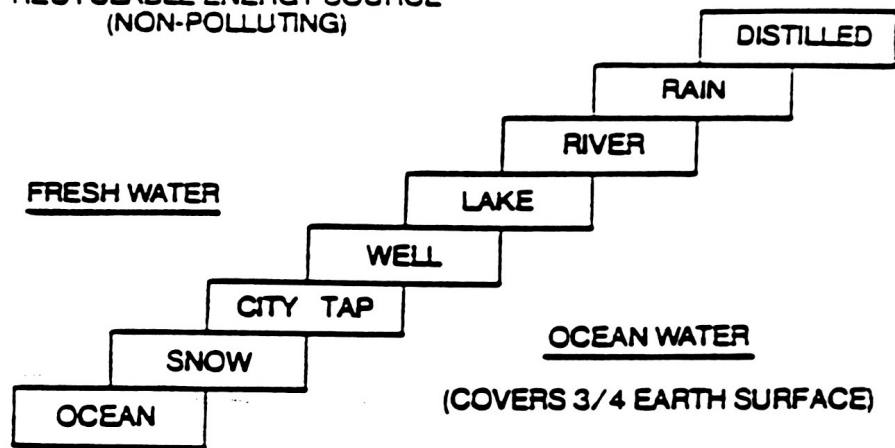

**FIG. 4: ELECTRICAL POLARIZATION OF THE
WATER MOLECULES OCCURS IN ALL
NATURAL WATERS**

Copyright © 1981 by Stanley A. Meyer

4

Operational Parameters of the Invention

THE FORMATION OF VOLTAGE ZONES

After it was discovered that the hydrogen and oxygen atoms in natural water could be electrically charged, all that was needed was the creation of two electrical voltage zones, opposite in electrical polarity, placed on either side of the water molecule. Simply by applying voltage potential, the oxygen atom, now with a negative (b-) electrical charge, is attracted to the positive (b+) electrical voltage zone. Likewise, the hydrogen atoms, now with a positive (b+) electrical charge, are attracted to the negative (b-) electrical voltage zone. In the repetition of this process, the water molecules are being split, releasing oxygen gas and energy in the form of hydrogen gas.

In order to capitalize on the electrical polarization of the water molecule and maximize the release of hydrogen energy, it is imperative that the process take place in a non-chemical environment. Stressing that this is simply a physical process, only natural water is utilized without any additives or chemicals. The voltage zones used are two non-oxidizing, non-corrosive, non-reactive, stainless steel excitor plates emerged in a non-chemical, non-reactive housing. Voltage, or potential energy, flows across the excitor plates, one plate being positive (b+) electrically charged and one being negative (b-)

electrically charged. Voltage moves across the plates, but the flow of amps is restricted. Since almost no amps flow across the zones, the process remains chemical free and energy consumption in the process is extremely low. The electronic circuit interfacing determines how the amps are restricted. Contaminants in natural water remain contaminants and have no effect upon the electrical polarization process.

VOLTAGE IS POTENTIAL ENERGY

In the electrical energy equation $\text{Power} = \text{Amps} \times \text{Voltage}$ (see Figure 5), voltage becomes potential energy since the flow of amps is restricted across the plates. Since the Fuel Cell uses voltage potential (remember, voltage is pressure or force within an electrical system called potential: unlike charges attract while like charges repel; voltage potential is used to electrically charge the atoms to disrupt the electron flow, covalent bonding, between the atoms) to economically split the water molecule, very little power is being used to release a terrific amount of energy. The hydrogen being released is two and a half times more powerful than gasoline. The Fuel Cell simply releases stored energy from natural water economically.

The pulse voltage frequency generators, as shown in Figures 11, 11A, and 34, are relatively small in comparison to a conventional amp generator. The low-cost features of the Fuel Cell make the system ideal for utilization: it uses free water, simply does not decompose during operations, and uses voltage potential that is not consumed during hydrogen gas production. These economic features of the Fuel Cell now establish natural water as a new, free, and abundant energy

ELECTRICAL POWER EQUATION:

$$P = I \times E$$

VOLTAGE POTENTIAL
(STATIC CONDITION)

AMP FLOW → POWER CONSUMED

**FIG. 5: VOLTAGE POTENTIAL PERFORMS
WORK WITHOUT AMP FLOW**

Copyright © 1981 by Stanley A. Meyer

source. After all, three-fourths of the earth's surface is covered with water...of which two thirds by atomic weight is hydrogen gas.

Furthermore, using natural water requires no refining process, no distribution network, nor special packaging.

PRODUCING HYDROGEN ON DEMAND

Until now, voltage potential has been used in two ways to operate the fuel cell: electrically charging the atoms of the water molecule to disrupt covalent bonding of the water molecule and to separate the liberated atoms for utilization. Another aspect is to attenuate the voltage potential to generate hydrogen gas on demand. This is simply done by manipulating the parameters of the voltage zones.

One technique to control gas production is to physically move the voltage zones, or plates, closer together, while keeping the voltage potential constant, as illustrated in Figure 6. Moving the voltage zones closer together causes a greater electrical force to be applied to the electrical polarization process...causing hydrogen to be produced exponentially.

Another way to control the hydrogen gas production is to maintain the electrical voltage zones in a fixed position, and increase the intensity of the electrical voltage potential (see Figures 9A, 9B and 16...Va, Vb, Vn) across the zones, as illustrated in Figure 7. Again, hydrogen gas is produced exponentially as voltage potential increases. The pulse voltage frequency potential is used to help restrict amp flow during the electrical polarization process. Voltage potential may be

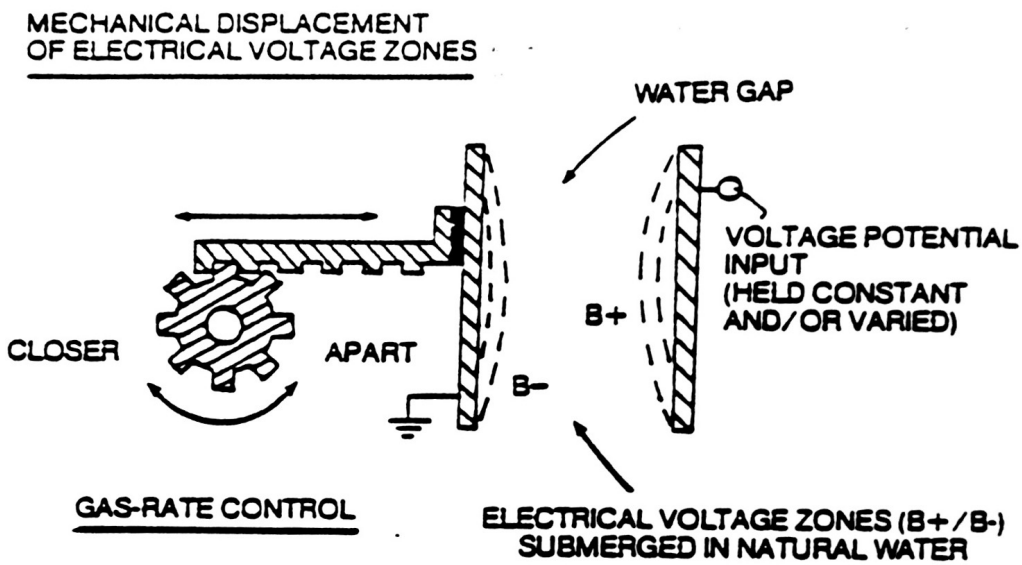

FIG. 6: HYDROGEN GAS-YIELD IS FURTHER INCREASED BY NARROWING WATER-GAP

Copyright © 1981 by Stanley A. Meyer

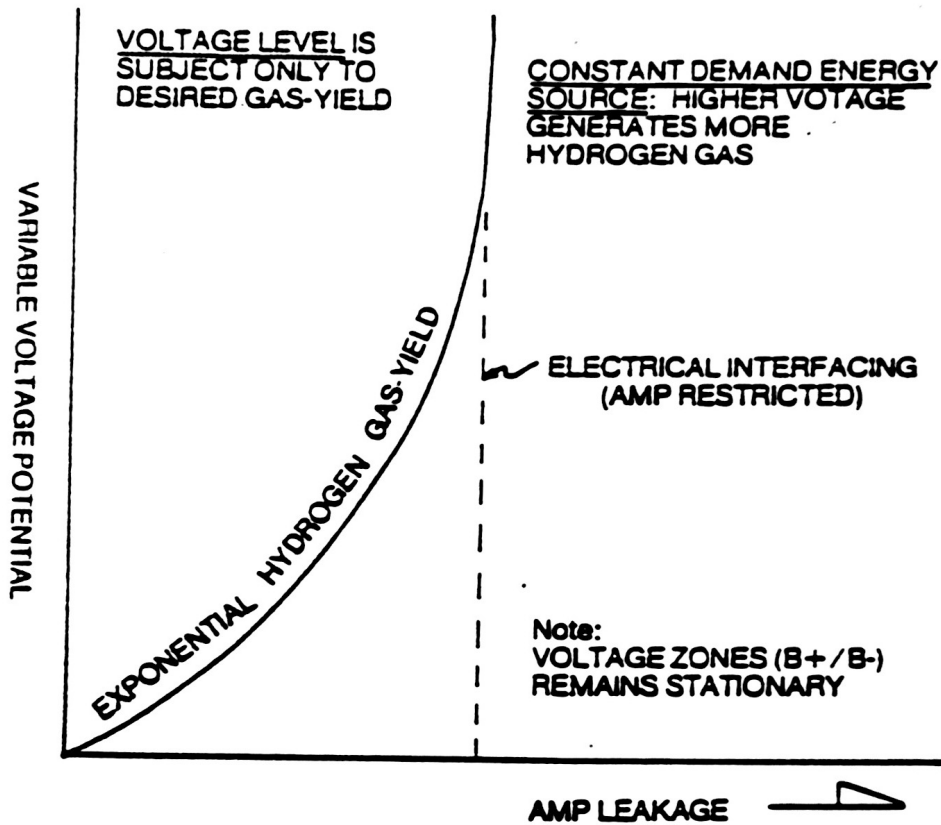
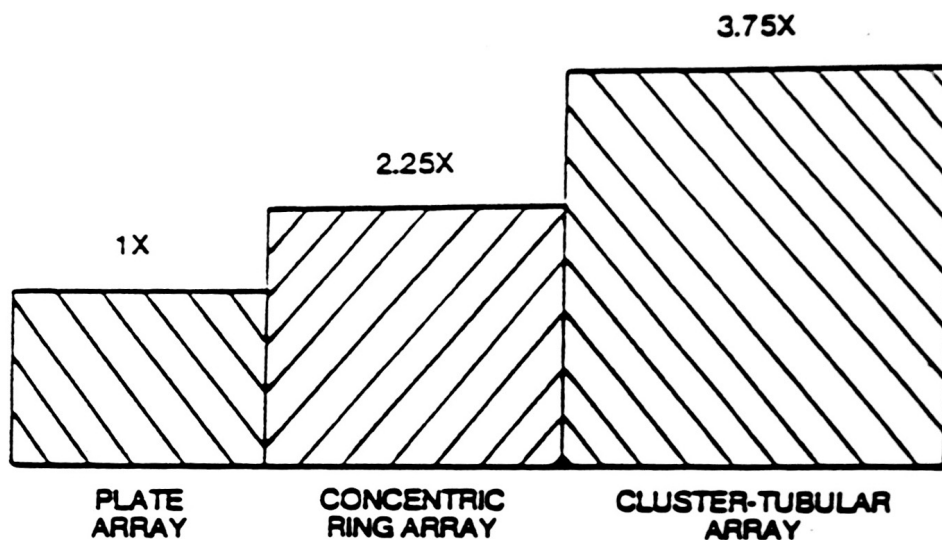

FIG. 7: DISSOCIATION OF THE WATER MOLECULE IS DIRECTLY RELATED TO APPLIED VOLTAGE

Copyright © 1981 by Stanley A. Meyer

EQUAL SURFACE AREA WITH
THE SAME APPLIED VOLTAGE



**FIG. 8: GEOMETRICAL-SHAPE OF THE
VOLTAGE ZONES (B+/B-) ALSO
ALTERS HYDROGEN GAS-YIELD**

Copyright © 1981 by Stanley A. Meyer

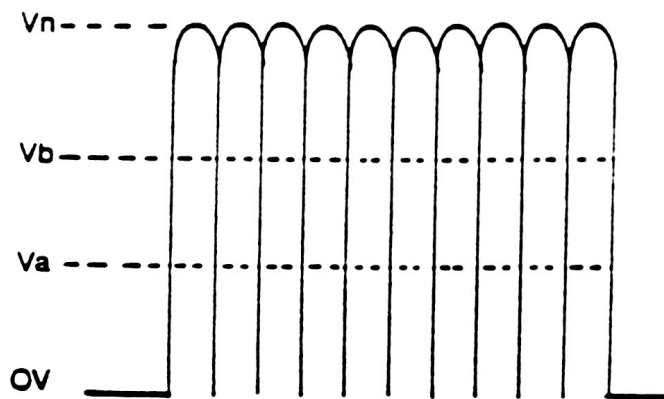

**FIG. 9A: VARIABLE PULSE-VOLTAGE
FREQUENCY RESTRICTS AMPS WHILE
CONTROLLING GAS-YIELD RATE**

Copyright © 1981 by Stanley A. Meyer

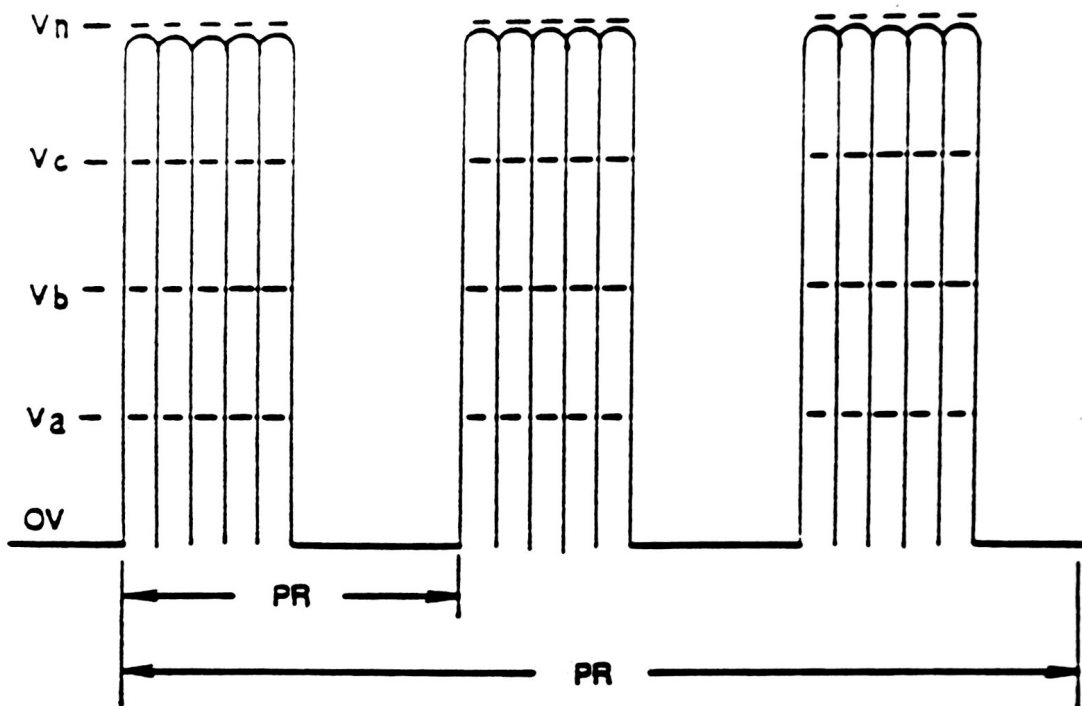

FIG. 9B: VARIABLE AMPLITUDE UNIPOLAR PULSE VOLTAGE FREQUENCY SUPER IMPOSED ONTO AN 50% DUTY-CYCLE PULSE-TRAIN DYNAMICALLY CONTROLS THE HYDROGEN GAS-RATE WHILE RESTRICTING AMP FLOW.

Copyright © 1981 by Stanley A. Meyer

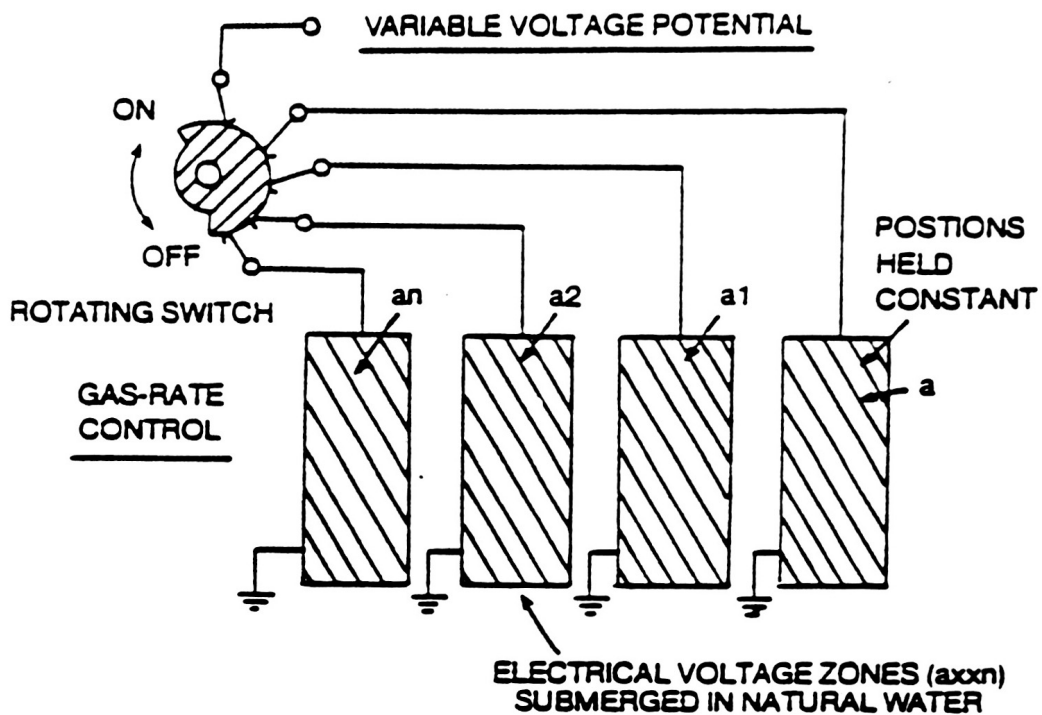

FIG.10: HYDROGEN GAS-YIELD IS ALSO RELATED TO PLANAR-SIZE OF VOLTAGE ZONES

Copyright © 1981 by Stanley A. Meyer

increased to any desired level to meet hydrogen gas production on demand. Zero to 20,000 volts range is quite normal at any frequency level.

Also, gas production is greatly manipulated by changing the physical design characteristics of the voltage zones (voltage zones taking on the shape of the excitor plate...skin effect). This includes increasing the size (height or width or diameter) of the zones, and/or the shape and configuration of the zones, as shown in Figure 8.

Finally, gas production is greatly manipulated by simply switching on and off, or pulsing, the electrical voltage zones in a variable, repetitive manner, as shown in Figures 9A, 9B and Figure 16. The higher the frequency of the voltage pulse, the greater the production of gas.

Coupled with this voltage pulsing is "segmentation." The voltage zones may actually be segmented, with areas of the zones physically removed at a given point, as illustrated in Figure 10. This reduces gas production. When the segments are reintroduced inside the Fuel Cell, gas production increases.

By combining these voltage potential parameters into a functional control system, as shown in Figures 11, 11A and 34, the Fuel Cell now becomes a constant demand generator. As energy is needed, simply vary the voltage potential parameters to meet the need. The Fuel Cell, therefore, needs no secondary storage system since hydrogen is being stored in the safest storage medium known to man until used...water. Can you not use water to extinguish a fire?

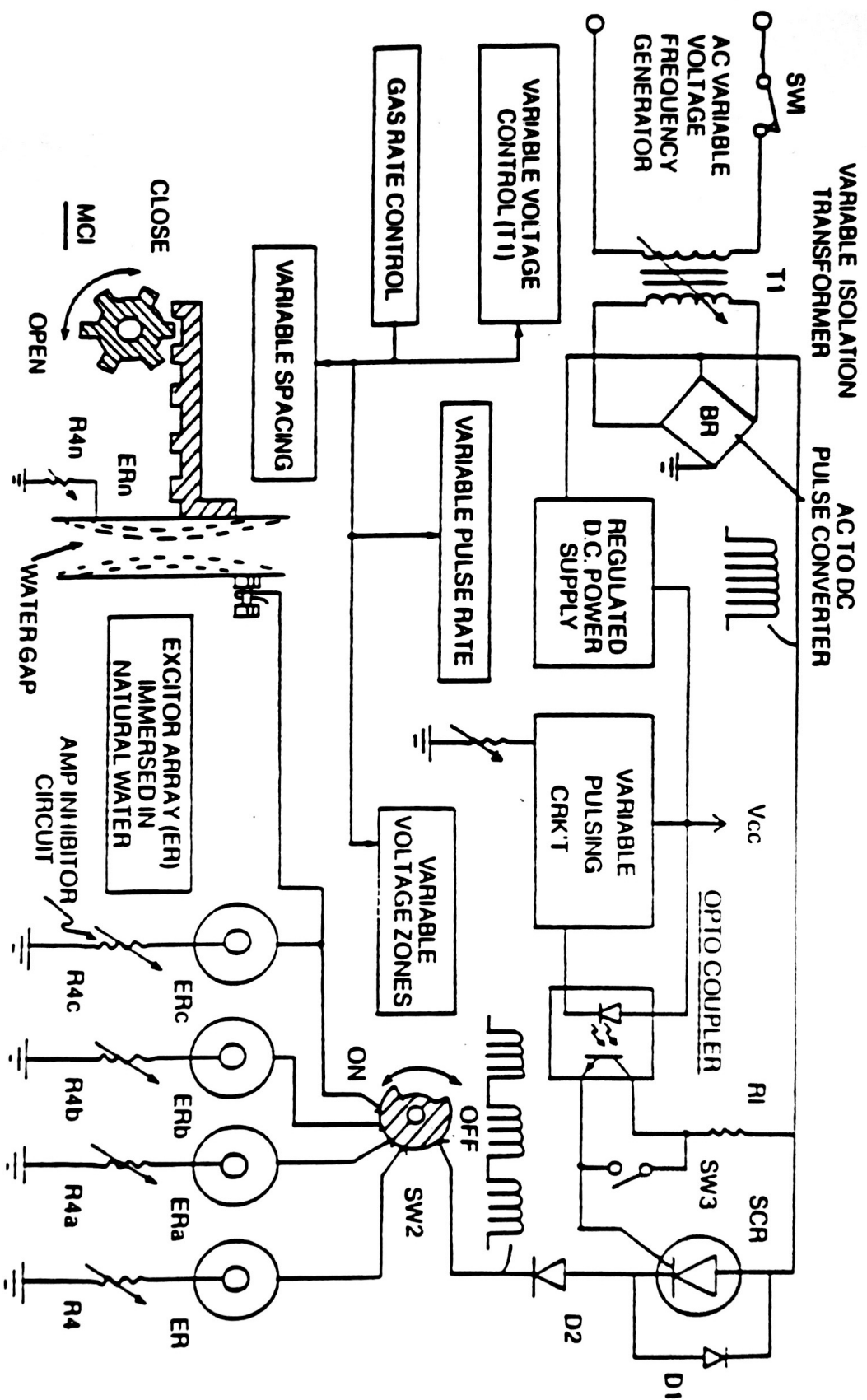

FIG. 11: INTEGRATED GAS-RATE CONTROL CIRCUIT
(Generating hydrogen gas on demand)

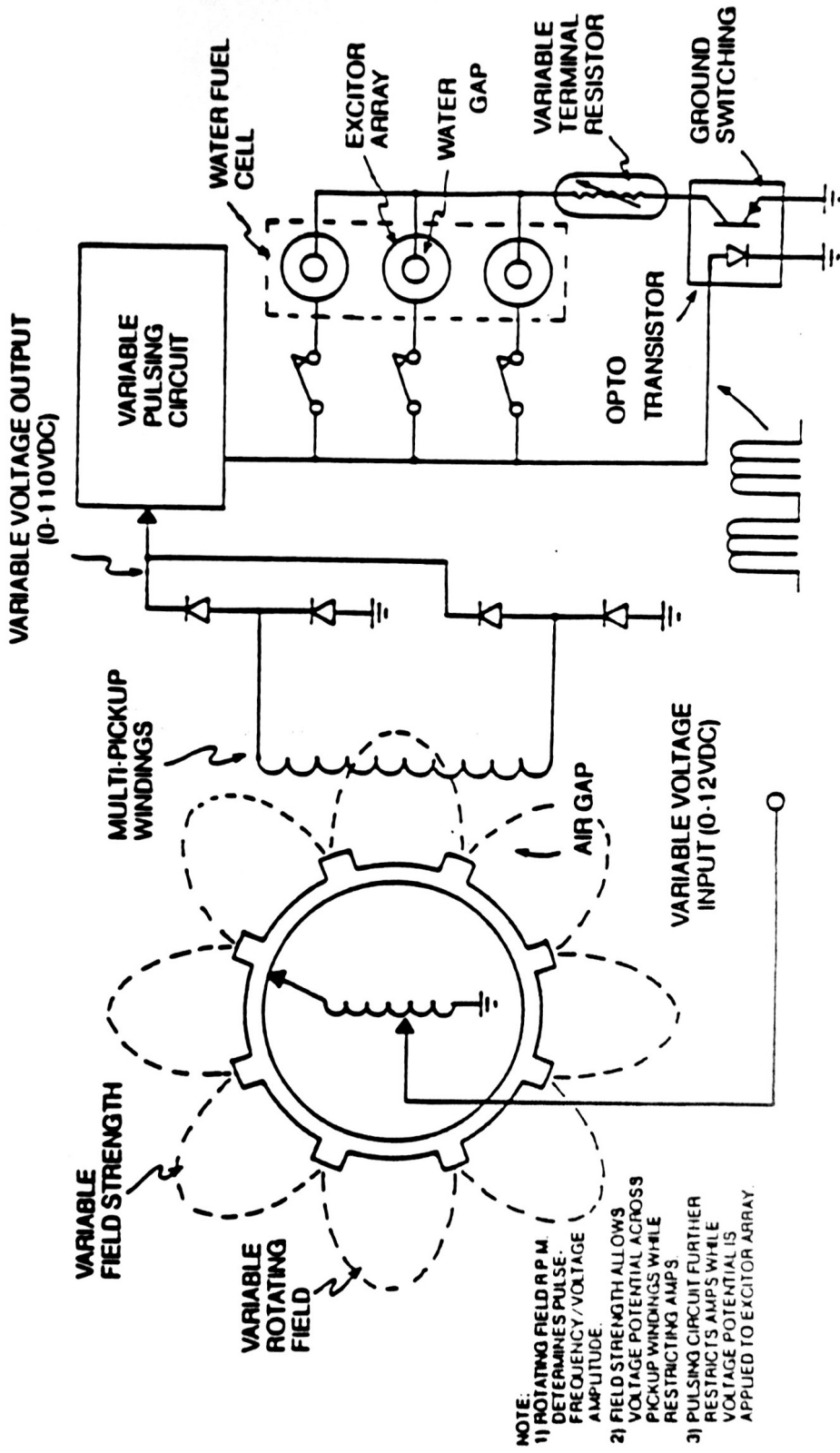

FIG. 11A: VARIABLE PULSE-VOLTAGE FREQUENCY GENERATOR (GENERATING HYDROGEN GAS ON DEMAND)

Copyright © 1981 by Stanley A Meyer

5

Mega Watt Gas Yield

The previous method of producing hydrogen gas via the application of voltage potential (pressure or force within an electrical system) is quite efficient, but there are several advance steps to the ELECTRICAL POLARIZATION PROCESS that increase hydrogen gas energy production astronomically from natural water. This is simply done through the use of a Resonant Cavity Fuel Cell, as so illustrated in Figures 12, 17, 19 and 20.

RESONANT ACTION AND THE PHENOMENA

The Resonant Action (as graphically depicted) within the Fuel Cell occurs in a systematic way. First an oscillating voltage field, or zone, is formed around a second oscillating voltage field, or zone, opposite in electrical polarity and forming a water zone in between. The two oscillating voltage zones are synchronized into a single repetitive wave form, as shown in Figures 9A, 9B and 16. As the water molecules are exposed to the reforming voltage zones, the hydrogen atoms become positive electrically charged while the oxygen atom becomes negative electrically charged...electrically polarizing the water molecule, as illustrated in Figures 2 and 3. The pulsating voltage zones also help restrict amp flow during the electrical polarization process.

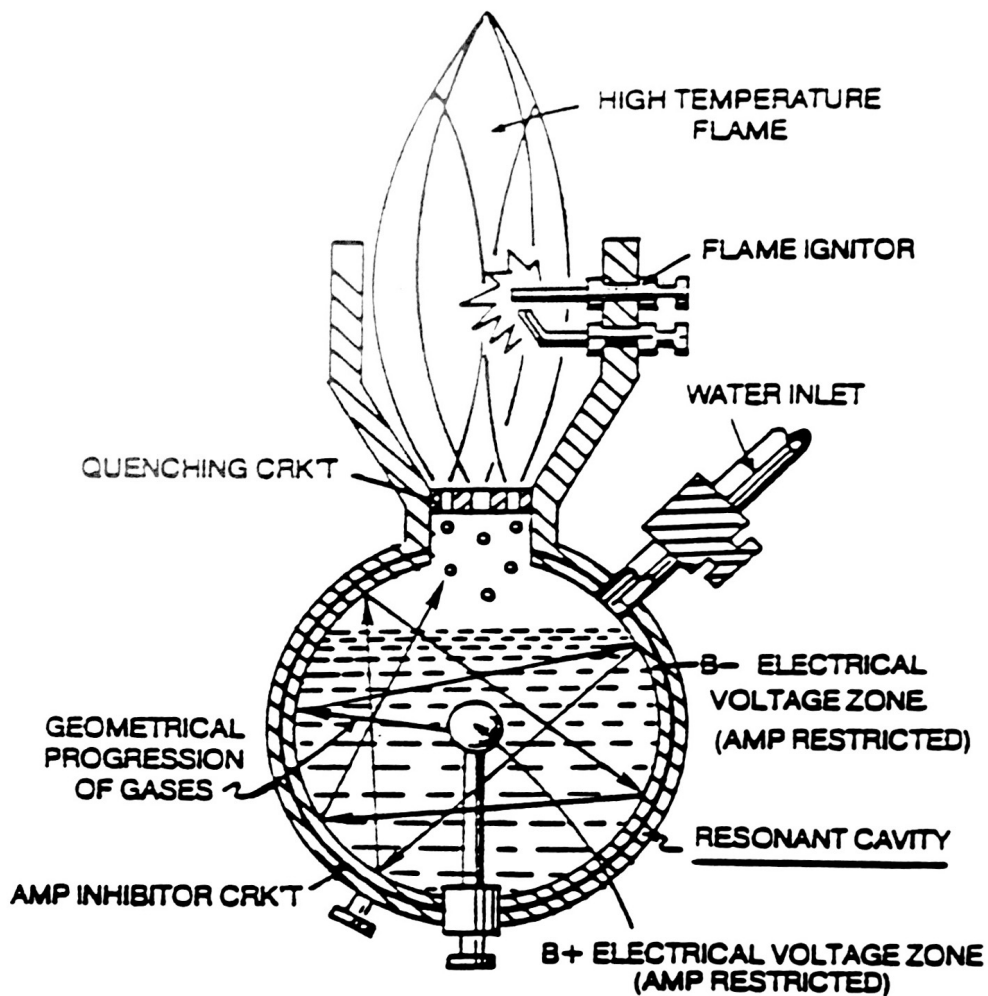

FIG. 12: ELECTRICAL VOLTAGE ZONES (B-/B+) FORMING A RESONANT-CAVITY

Copyright © 1982 by Stanley A. Meyer

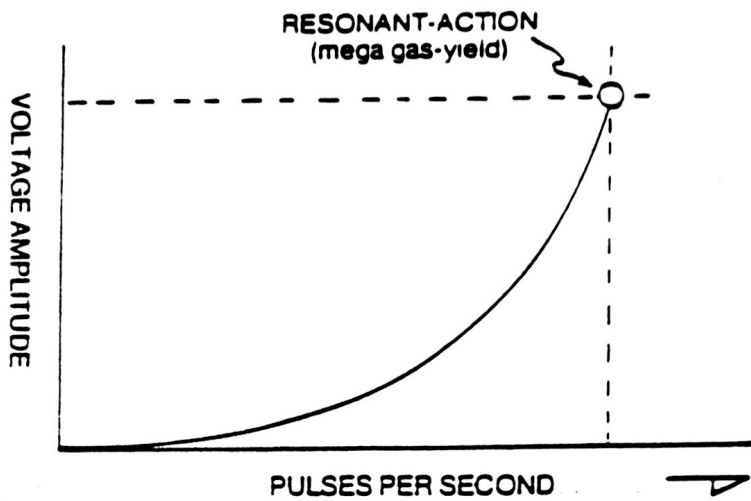

FIG. 13: LONGITUDINAL RESONANT - CAVITY

Copyright © 1982 by Stanley A. Meyer

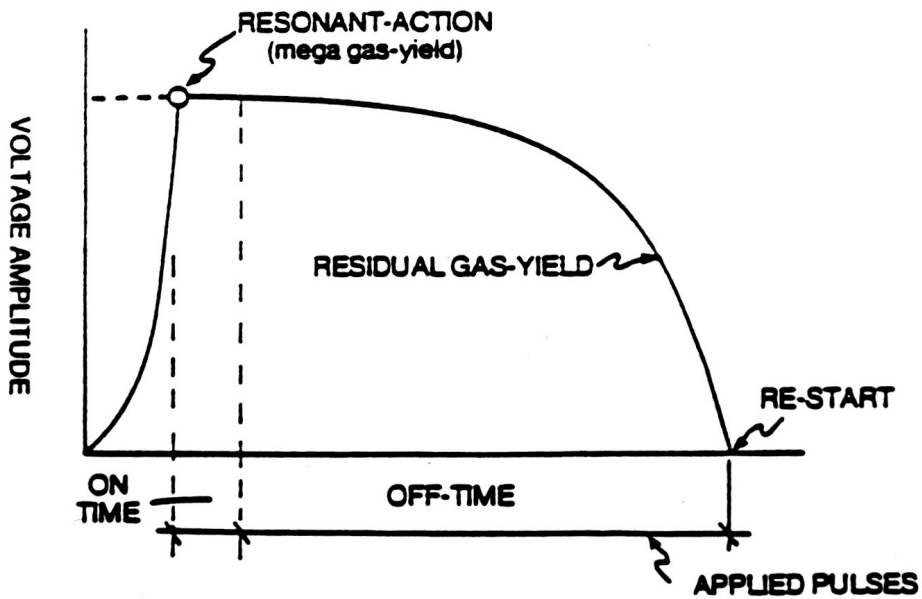

FIG. 14: SPHERICAL RESONANT-CAVITY.

Copyright © 1982 by Stanley A. Meyer

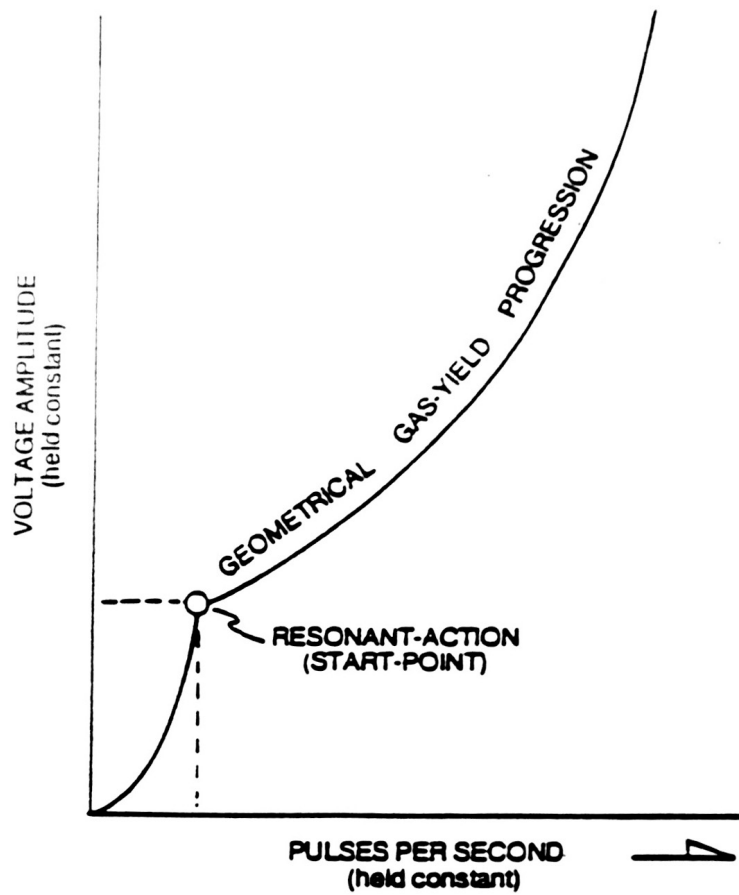

FIG. 15: SPHERICAL RESONANT CAVITY

Copyright © 1982 by Stanley A. Meyer

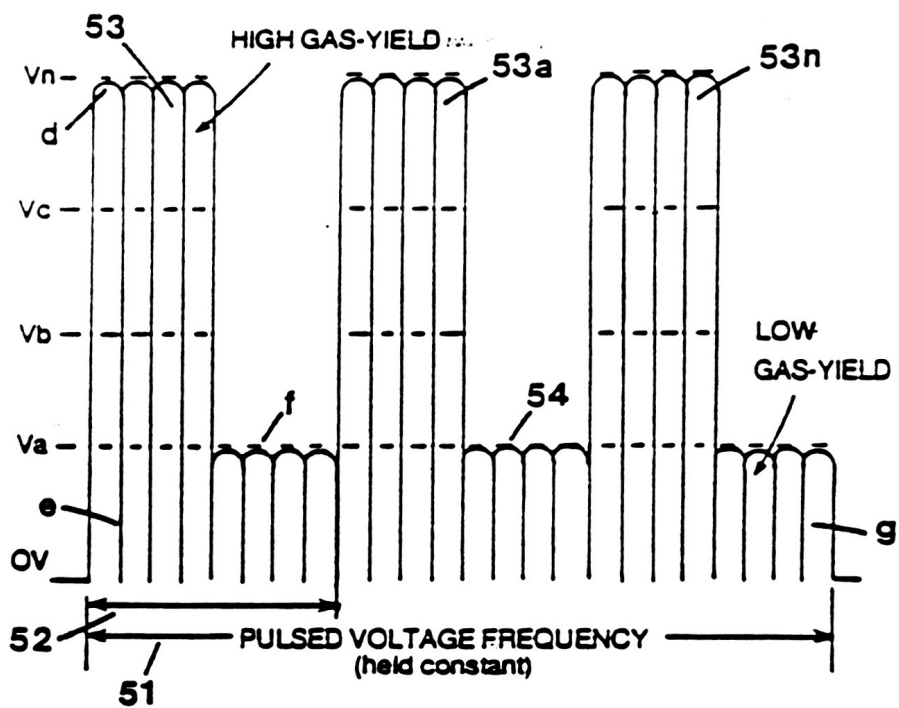

FIG. 16: VARIABLE VOLTAGE AMPLITUDE CONTROLS RESONANT-ACTION OUTPUT

Copyright © 1982 by Stanley A. Meyer

Once the electrical polarization phenomenon occurs, the covalent bonding, or sharing, of electrons between atoms of the water molecule ceases to exist since the positive electrically charged hydrogen atoms attract the free floating negative charged electrons while, at the same time, the negative electrically charged oxygen atom repels the moving electrons...thereby stabilizing the energy levels of the atoms...separating the water molecule into its component parts...releasing energy in the form of hydrogen gas and oxygen gas, as illustrated in Figure 3. The opposite polarity attraction that now exists between the liberated electrically charged atoms and the stationary electrical voltage zones further aids the splitting process by imparting a physical impact (particle impact) on neighboring molecules undergoing the electrical polarization process.

Since the voltage zone that forms the resonant cavity outer wall momentarily entraps the liberated atoms, the moving atoms are accelerated and deflected among other molecules being split...causing compound action, as so illustrated in Figures 13, 14 and 15. This compounding action continues to increase as more atoms are being liberated from other water molecules. The repetitive pulse voltage frequency potential continues the compounding action, whereas an increase in voltage amplitude speeds up the compounding action under controlled means. Simply moving liberated atoms back and forth uniformly through the electrical polarization process in a repetitive manner establishes Resonant Action within the Fuel Cell.

RESONANT ACTION ENHANCEMENT

Resonant Action enhancement beyond the influence of pulse voltage potential is accomplished in several ways. In the area of electron deflection, the electrically charged atoms moving toward the water molecules further disrupt the covalent bonding, while at the same time increasing the electrical charges inside the Fuel Cell during the electrical polarization process. Increasing the number of electrically charged atoms within the Fuel Cell directly increases the voltage charges within the same cell while applied pulse voltage frequency potential remains the same...increasing gas yield while power input remains constant.

In terms of design application, the resonant cavity is multi-tier with other resonant cavities of similar design in a sequential manner, as shown in Figures 20D, 20H, and Figure 3. As the electrical polarization process occurs, the liberated and electrically charged atoms are recycled inside the resonant cavity prior to atom injection into the next cavity-structure undergoing the same recycling process. The orderly and sequential progression of the moving charged atoms through the cavity-array increases the voltage charges per stage since more atoms are being allowed to interact with each preceding stage. To increase gas yield even further, additional atom recycling cavities are affixed to the vertical array to meet a predetermined gas need.

The interaction of the laser beam or light energy (see Figure 20D) with the liberated atoms inside the resonant cavity during the electrical polarization process causes the free floating atoms to either lose or gain electrons...causing said atoms to become electrically charged and used as herein described. The expelling

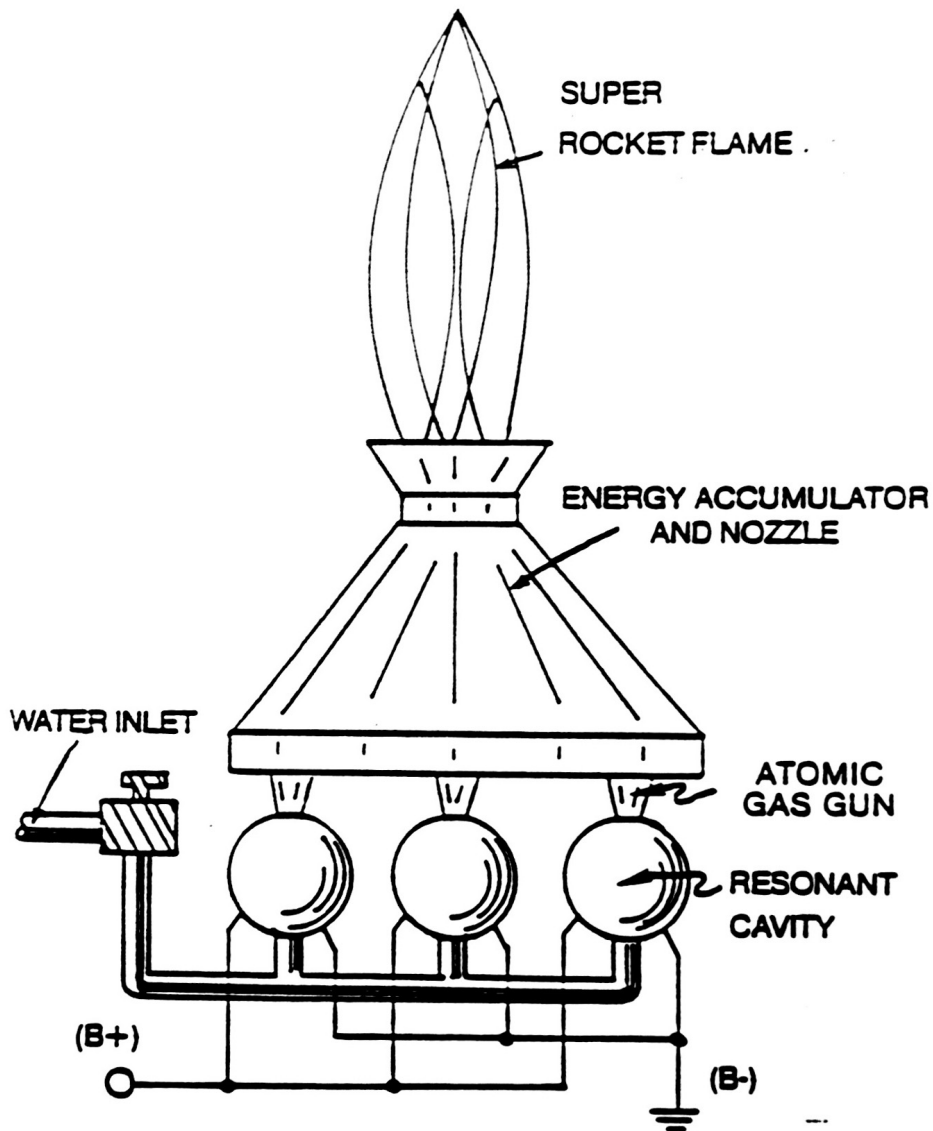

**FIG.17: RESONANT-CAVITIES FORMING
THE WATER VESSEL**

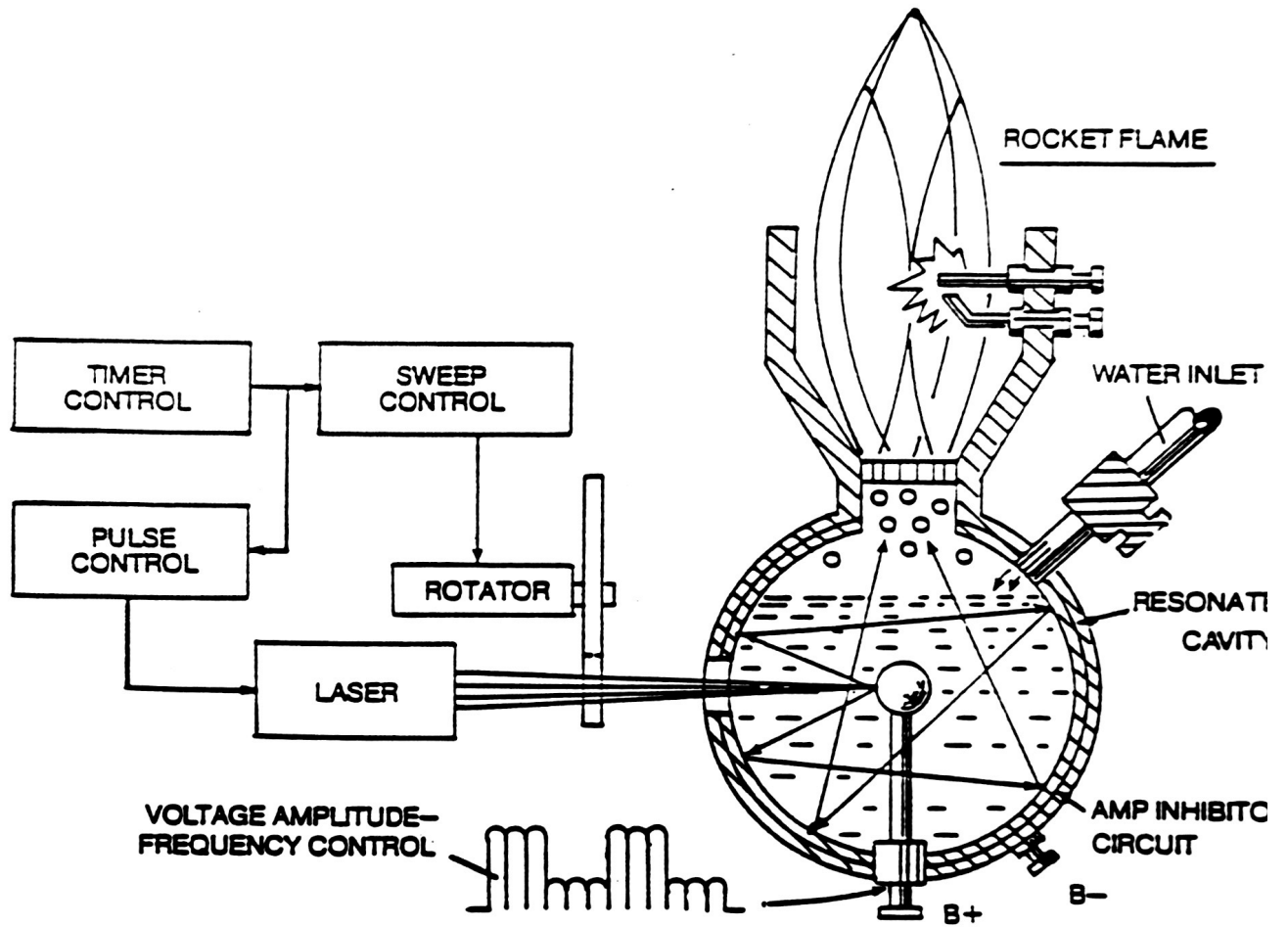

FIG. 19: LASER INJECTED RESONANT-CAVITY

Copyright © 1983 by Stanley A. Meyer

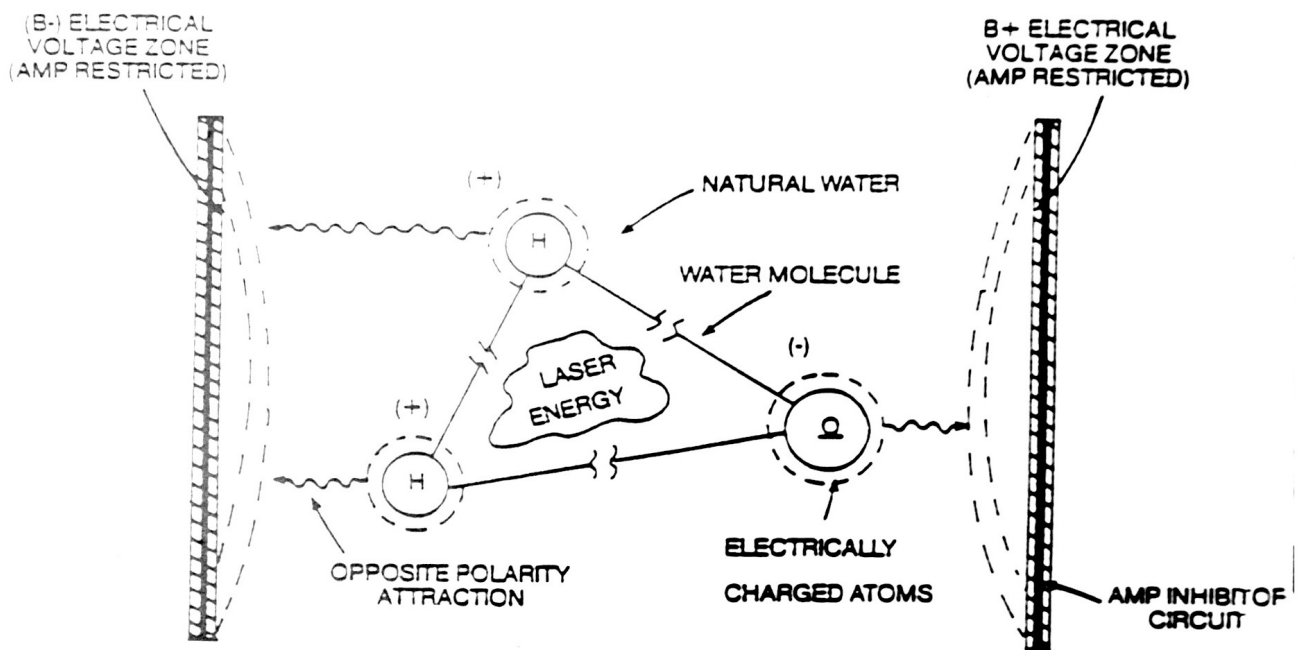

FIG. 18: PHOTON ENERGY AIDS RESONANT-ACTION

Copyright © 1983 by Stanley A. Meyer

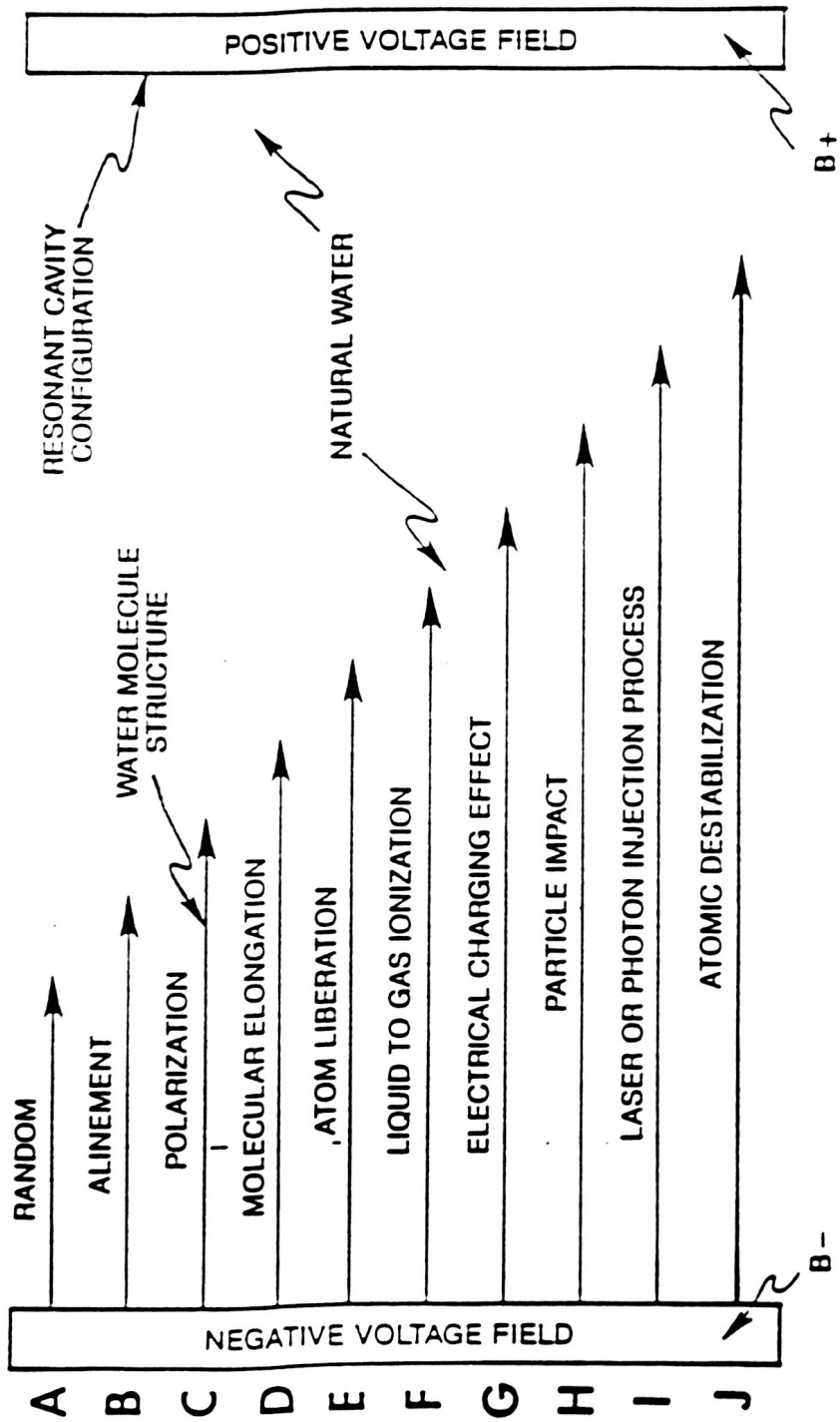
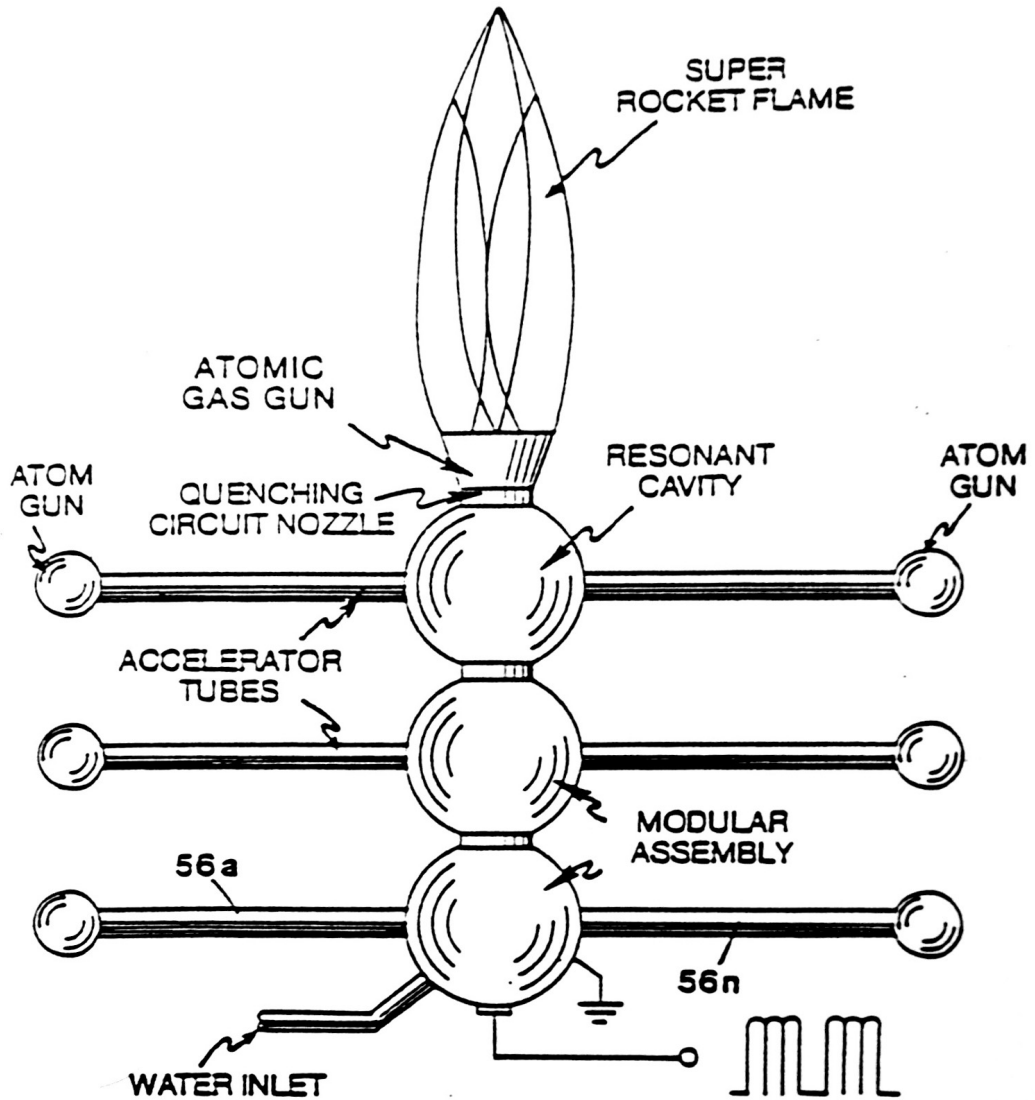

FIG. 20A: HYDROGEN FACTURING PROCESS PRIOR TO GAS IGNITION

COPYRIGHT © 1983 BY STANLEY A. MEYER



**FIG.20: ATOM INJECTED RESONANT-CAVITY
(INTERLOCKING MODULES)**

COPYRIGHT © 1986 BY STANLEY A. MEYER

charged atoms of Figure 20D are used in conjunction with the electrical polarization generator of Figure 40 to form the regenerative energy feedback network of Figure A as pictorially illustrated in Figure 3. This process simply uses the component parts of water to produce electricity without consuming the charged atoms prior to gas ignition.

ATOM INJECTED RESONANT ACTION: THE ROCKET ENGINE

To capitalize on this electrical charge phenomena still further, the atom-injected resonant cavity of Figure 20 was developed. The atom guns are smaller resonant cavities that liberate and expell electrically charged hydrogen and oxygen atoms into accelerator tubes for particle acceleration. Once accelerated to maximum speed, the projected electrically charged atoms are injected into a larger resonant cavity...providing particle impact...supercharging the electrical field inside the central fuel cell for even higher gas yield. This electrical charging process is ideal since natural water is the prime source for the electrically charged atoms. This process is further exemplified in the verticle-array fuel cell of Figure 20B and power loading circuit of Figure 20D. Note how the high voltage pulse is sequentially sync with the pulsing laser during each cavity stage.

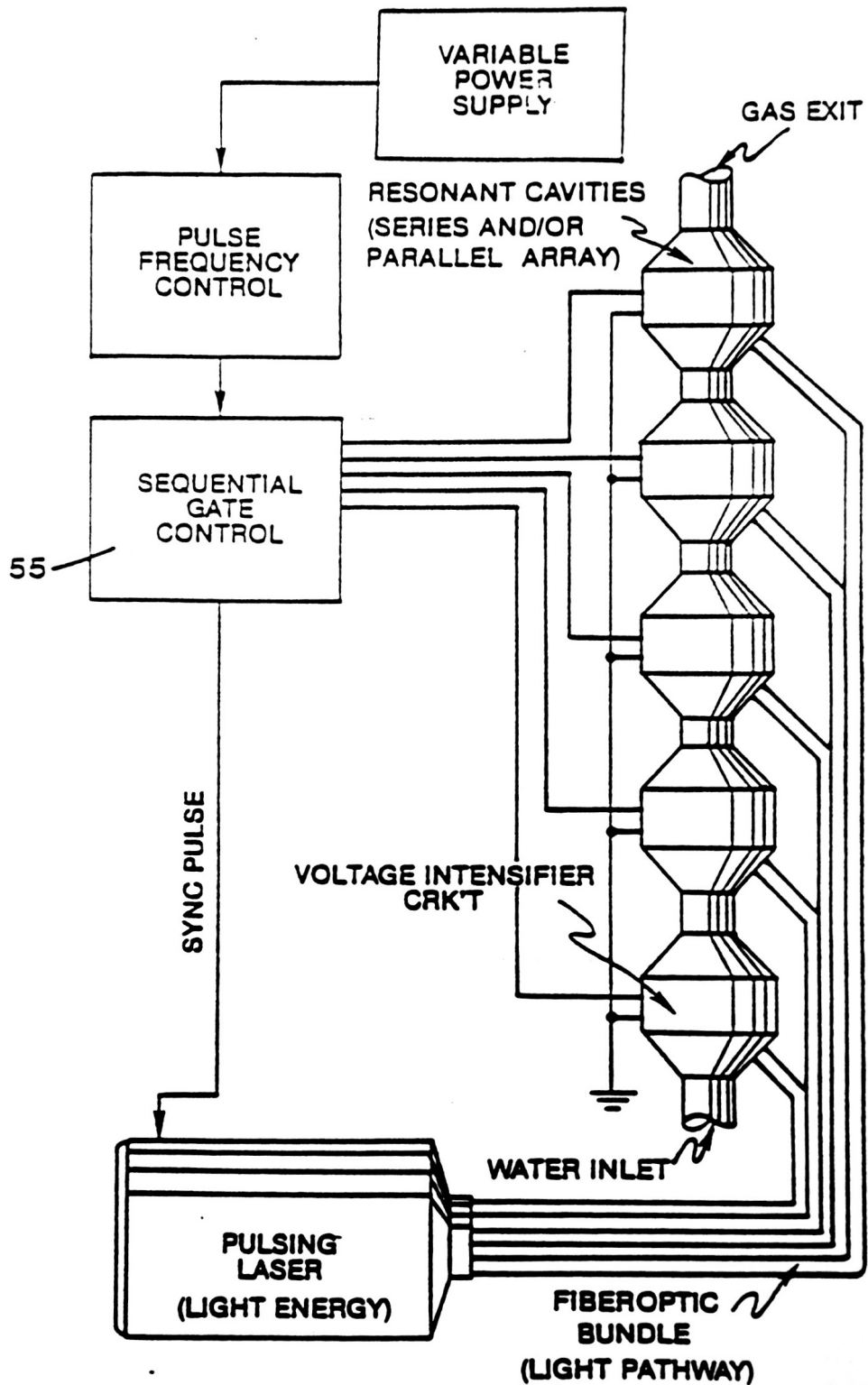

FIG. 20D: POWER LOAD DISTRIBUTION

COPYRIGHT © 1982 BY STANLEY A. MEYER

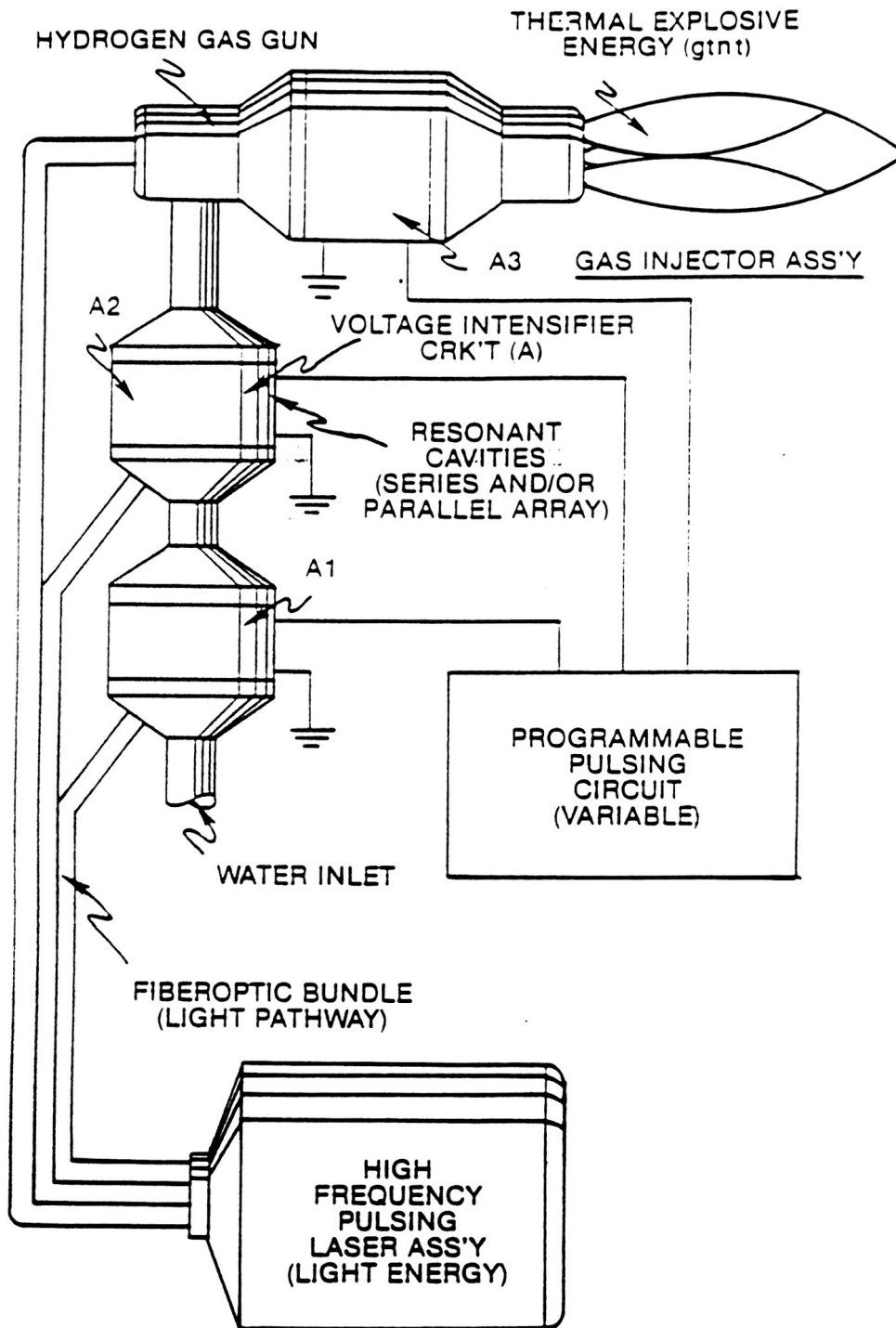

FIG. 20H: GAS INJECTOR FUEL CELL

COPYRIGHT © 1983 BY STANLEY A. MEYER

LASER INJECTED RESONANT ACTION: THE THROTTLE BOOSTER

Since laser or light energy is electromagnetic energy having zero mass and no electrical charge, particle impact within said resonant cavities is accomplished by ionizing the atoms of said water molecule. As the laser energy is superimposed onto the electrical polarization process, as shown in Figure 18 and 19, the photon or light energy (see Figure 19A) is being absorbed by the water molecule atoms(s) nuclei. Once the electrical polarization process occurs, many liberated atoms (including ambient air gases) become positive electrically charged when said atoms lose an electron, forming a positive charged ion.

The electromagnetically primed (atom absorbing light energy) hydrogen atom may now accept said liberated electron, forming a negative charged ion.

By simply attenuating said high intensity voltage pulse, said charged atoms are set into motion...causing particle impact or particle collision during the electrical polarization process. The liberated negatively charged electrons are also set into motion to help aid or boost said particle impact. The uniform movement (particle oscillation) of said electrically charged particles within said resonant cavity is now called compounding-action or resonant-action.

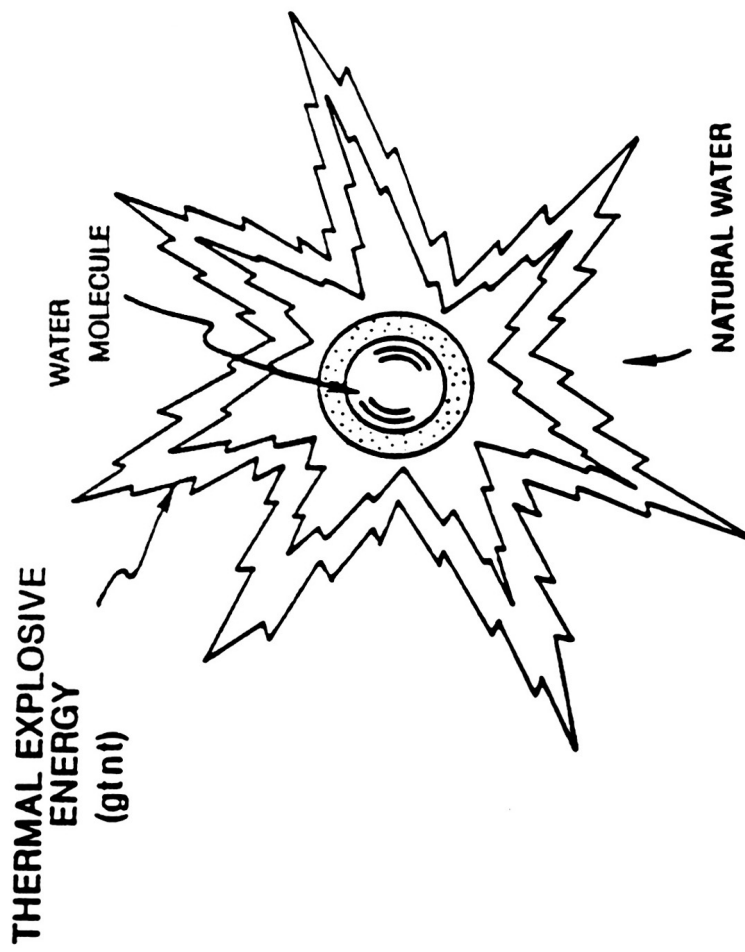

HYDROGEN FRACTURING PROCESS

COPYRIGHT © 1963 BY STANLEY A. MEYER

Hydrogen Gas Gun Technology

To sustain energy-yield beyond the gas-flame combustion state (sustaining and maintaining a hydrogen/oxygen flame), the Electrically Charged (atom having missing or more than normal amount of electrons) and "Optically Primed" (atoms absorbing photon energy) combustible gas ions being expelled from Resonant Cavity Array (Figure 20D) now enters into and through a Hydrogen Gas Gun Assembly placed on top of and interlocked with said Resonant Cavity Assembly, as illustrated in Figure 20H. The moving combustible gas ions are subjected to higher energy levels (Voltage and Laser Stimulation) while being exposed to an Electron Extraction Process for the purpose of further destabilizing the mass/electrical equilibrium of said gas atoms. The Voltage Intensifier Circuit simply prevents electron replacement during voltage stimulation.

The specially treated combustible gas ions are now subjected to thermal stimulation via an Optical Thermal Lens Assembly...forcing said Electrically Charged and Laser Primed combustible gas ions to reach critical state...causing said gas ions to decay...releasing thermal explosive energy beyond the gas flame stage. **The point of atomic energy-yield is simply reached when the electron deficient oxygen atom (having less than normal amount of electrons) locks onto and captures the hydrogen atom electrons prior to and during thermal-combustion stimulation. The thermal explosive energy-yield is known as the "Hydrogen Fracturing Process."**

Together, the Optical Thermal Lens Nozzle, the Hydrogen Gas Gun, and Resonant Cavity Assembly forms a design variable Water Fuel Cell that is cost effective as to retrofit energy systems.

6

Fuel Cell Economics

DESIGN TO RETROFIT

Due to the discovery of the electrical charging of the water molecule and the use of voltage zones for splitting water into hydrogen and oxygen, the Fuel Cell is easily adaptable to all types of energy needs. Not only that, but the Water Fuel Cell is a retrofit system that does not require drastic changes in the energy consuming device. The simple, yet staggering design of the Fuel Cell lends itself to many other advantages over traditional energy sources; see Figure 21.

A PHYSICAL PROCESS

Since voltage, a potential energy, is used for the electrical polarity zones, the entire process of splitting the water molecule is a physical one. Amps are restricted in the electrical polarization process, so there is almost no chemical reaction in the environment of the Fuel Cell. Since chemical interaction is not required during the electrical polarization process, any form of natural water may be used for the extraction of hydrogen as fuel. Rain water, well water, tap water, river water, reservoir water, snow, distilled water, and even ocean water may be used in the Fuel Cell. Salt water has no adverse effect upon the Fuel Cell because amps are restricted. Salt and other minerals in the water are contaminants that are simply discarded. They

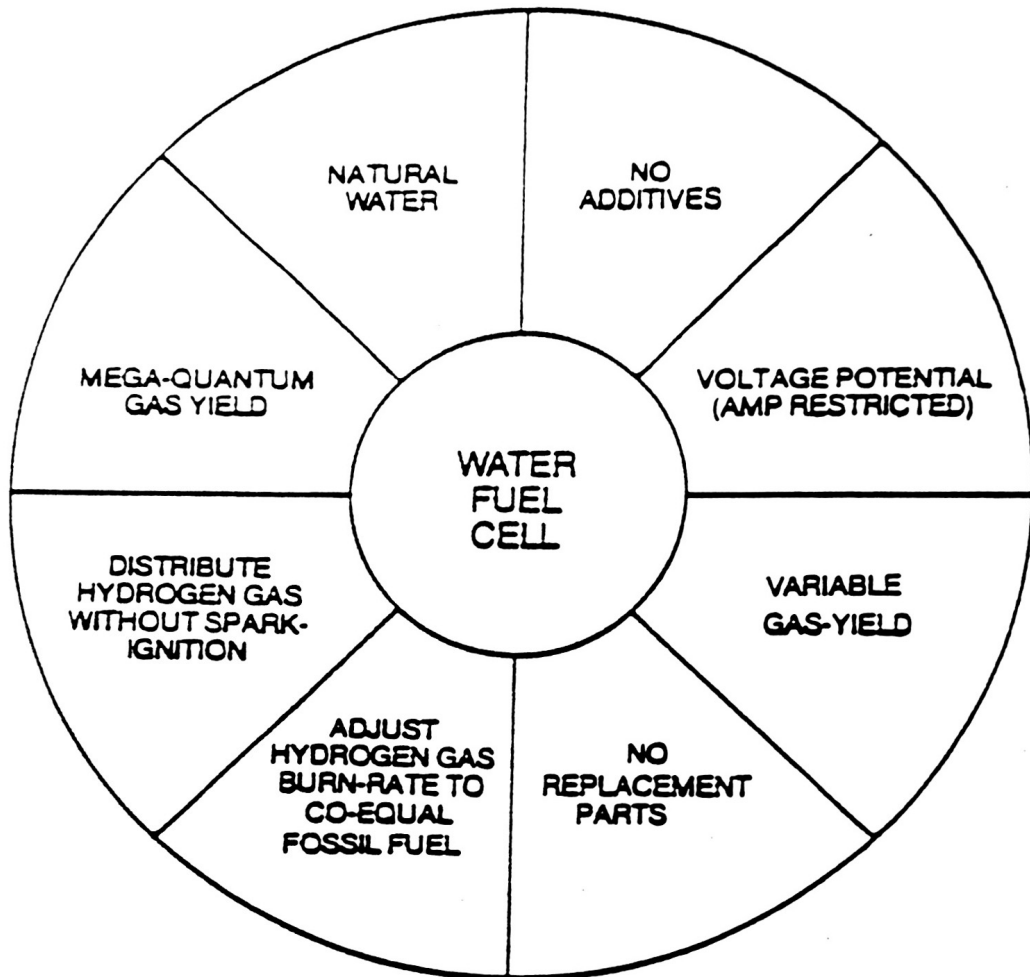

FIG. 21: THE WATER FUEL CELL CAN BE DIRECTLY RETROFITTED TO EXISTING ENERGY-CONSUMING DEVICES WITHOUT SYSTEM-CHANGE

Copyright • 1981 by Stanley A. Meyer

do not disrupt the normal function of the Fuel Cell. So, how cheap is water?

HYDROGEN: MORE POWERFUL THAN FOSSIL FUELS

Due to the inherent properties of the Water Fuel Cell, a little energy is being consumed to release a tremendous amount of energy in the form of hydrogen gas for use as fuel. By atomic weight (NASA test data), hydrogen is two and a half times more powerful than gasoline. Two thirds of a gallon of water contains hydrogen. So, how powerful is water?

WHAT'S THE COST OF WATER?

There are no expensive forms of chemical additives that have to be mixed to the water for hydrogen production.

You do not have to process the natural water in any fashion.

WHAT'S THE COST OF VOLTAGE?

The system is a voltage device, not an amp device. Voltage is a potential energy, not a consumed energy. Because of this, there is almost no consumption of power to split the water molecule into its component parts. The cost of voltage is negligible when amps are restricted.

Simply by varying the voltage to the system, or the physical parameters of the system, production of gas will increase exponentially. But energy consumption does not increase even if voltage is increased.

FUEL CELL LONGEVITY

Since the Fuel Cell is a non-chemical device, the use of non-oxidizing, non-reactive, non-corrosive materials provides for a system that has an extremely long life (lab tested .0001/yr) and does not need replacement parts. The system will not self destruct during gas production.

FUEL CELL MEETS THE NEED.

Because of its operational properties, the Fuel Cell may take on any form or size. The flexibility of design allows for use in any application.

The pulse voltage frequency generator applied to the Fuel Cell is very small in comparison to traditional on-site power generators. A large generator is simply not needed when voltage is only being used.

Because the Fuel Cell may take on any geometrical configuration and the pulse voltage generator is design-flexible, the energy source may be retrofitted to any energy-consuming devices. Simply adjust the size to meet the need.

OTHER FUEL CELL FEATURES

The Fuel Cell takes advantage of existing manufacturing technology and standard material for construction. There is no need to design new electronic components or develop exotic materials to implement the Fuel Cell into the marketplace.

The cost of the Fuel Cell is extremely low as compared to the cost of using conventional energy sources. Water is simply free energy

without any overhead refining cost or packaging expense. Water is simply reclaimed and recycled when the hydrogen energy is used in the form of heat.

There is no additional cost involved when adjusting the hydrogen burn rate to co-equal fossil fuels (see Figures 23 and 24) since the Fuel Cell utilizes natural water as the gas-mixing regulator. The gas mixture remains the same regardless of the gas rate of the generator.

The same gas mixture derived from natural water is also used without added cost to prevent spark-back into the Fuel Cell and distribution lines, as illustrated in Figure 25.

In conclusion, the Fuel Cell simply produces and renders hydrogen gas safer than natural gas without any additional cost beyond the cost of voltage. Remember, water is free.

7

Hydrogen Gas Utilization

THE NEED TO RENDER HYDROGEN SAFE

Not only can the Fuel Cell economically produce a huge amount of hydrogen gas on demand, it can also adjust the burn rate of the hydrogen gas to co-equal the burn rate of fossil fuels without additive chemicals. For example, to run a typical automobile on hydrogen gas without altering the engine or performance, the hydrogen gas is automatically adjusted to co-equal the burn rate of gasoline or diesel fuel, as shown in Figures 22 and 23. The Fuel Cell can also duplicate the burn rate of natural gas or other burnable fuels now being used in the marketplace. The Fuel Cell simply has the ability to safely and effectively render hydrogen as a useful fuel and does it economically. It also means that the Fuel Cell can be retrofitted to any type of existing power system using gas fuel.

QUENCHING CIRCUIT: ANTI SPARK-BACK

The Fuel Cell accomplishes this by using a hydrogen quenching circuit (see Figure 24) with the use of natural water. This small, button-sized circuit allows for the adjusting of the burn rate to support a sustained hydrogen-oxygen flame well over 2,500 degrees Fahrenheit without any spark-back into the Fuel Cell. It also helps

keep the gases uniformly mixed inside the Fuel Cell during gas production.

SUSTAINED HYDROGEN FLAME ON DEMAND

During the splitting of the water molecule, ambient air (supplied by the water and having gases that do not support combustion) passes through the very small quenching circuit with the hydrogen and oxygen gases prior to flame combustion. The non-combustible gases act as a modulator that reduces the speed at which the oxygen atom unites with the hydrogen atom to cause flame combustion. More specifically, the non-combustible gases associated with ambient air entrapped in natural water act as a dilutant that allows the hydrogen to burn at a rate equal to fossil fuels. The water itself acts as a gas-mixing regulator where the gas-mixing ratio remains constant regardless of the rate of gas production. Again, no costly manufacturing process is needed to convert hydrogen to fossil fuel burning levels. If for some reason you need a flame temperature greater than 2,500 degrees F., simply reduce the amount of non-combustible gases being mixed with the hydrogen. If you need the flame temperature to be lowered, simply recycle the expelled flame gases (ambient air gases exposed to the sustained hydrogen flame) back into the burning process. These gases further dilute the hydrogen burn rate. However, gas production is still dictated by demand, and mixing rate maintained regardless of the rate of gas generation. The hydrogen flame is sustained and maintained at all times during Fuel Cell operations.

HYDROGEN AS A CLEAN BURNING FUEL

The by-product of burning hydrogen and oxygen is simply water mist when the Fuel Cell utilizes a specially designed catalytic block that ensures almost one hundred percent conversion of the Fuel Cell burnable gases. The catalytic block, as used in the hydrogen reclaim system of Figure 39, accomplishes this gas conversion process in a systematic way. First, the catalytic block entraps all combustible gases (gases expelled from the flame) that have not undergone the flame burning process of combustion. The catalytic block re-exposes the escaped and entrapped burnable gases to the sustained hydrogen flame for gas combustion...eliminating any and all unused hydrogen and oxygen atoms...by combining these free-floating atoms to form water vapor when ignited. This second stage burning process superheats the catalytic block to further aid the combustion process. Once the oxygen and hydrogen atoms are completely locked into the water molecule formation, the atoms are consumed and cannot unite with other ambient air gases. For example, Nitrous Oxide (N_2O) cannot form since there are no oxygen atoms available to unite with the non-combustible nitrogen gas to form an oxide gas. Likewise, Nitrous Acid (HNO_2) in solution cannot form since there are no hydrogen atoms available to unite with nitrogen and oxygen atoms to form an acid in solution. Remember, there are no oxygen atoms present to help form the acid base. The catalytic block simply renders the Fuel Cell environmentally safe. This simply means that the water vapor produced from the Fuel Cell can be recycled back into the atmosphere to form rain which can be

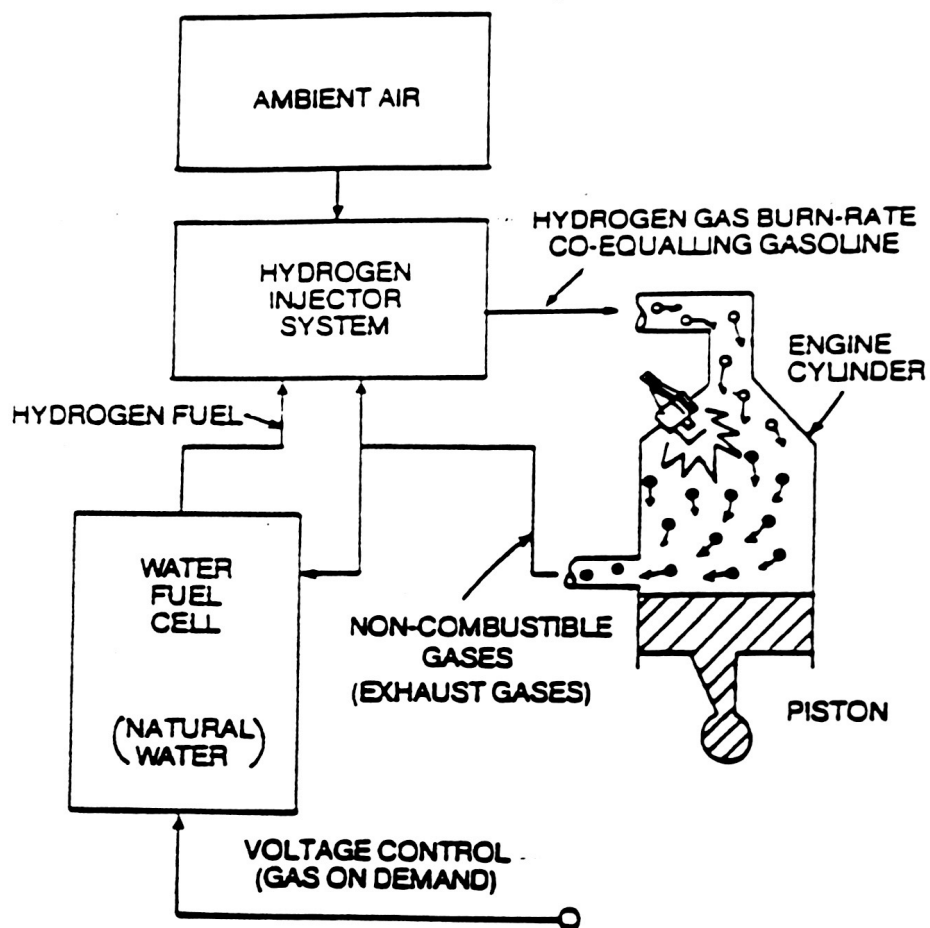

FIG. 22: WATER FUEL CELL RETROFITTED TO AN INTERNAL COMBUSTION ENGINE

Copyright © 1981 by Stanley A. Meyer

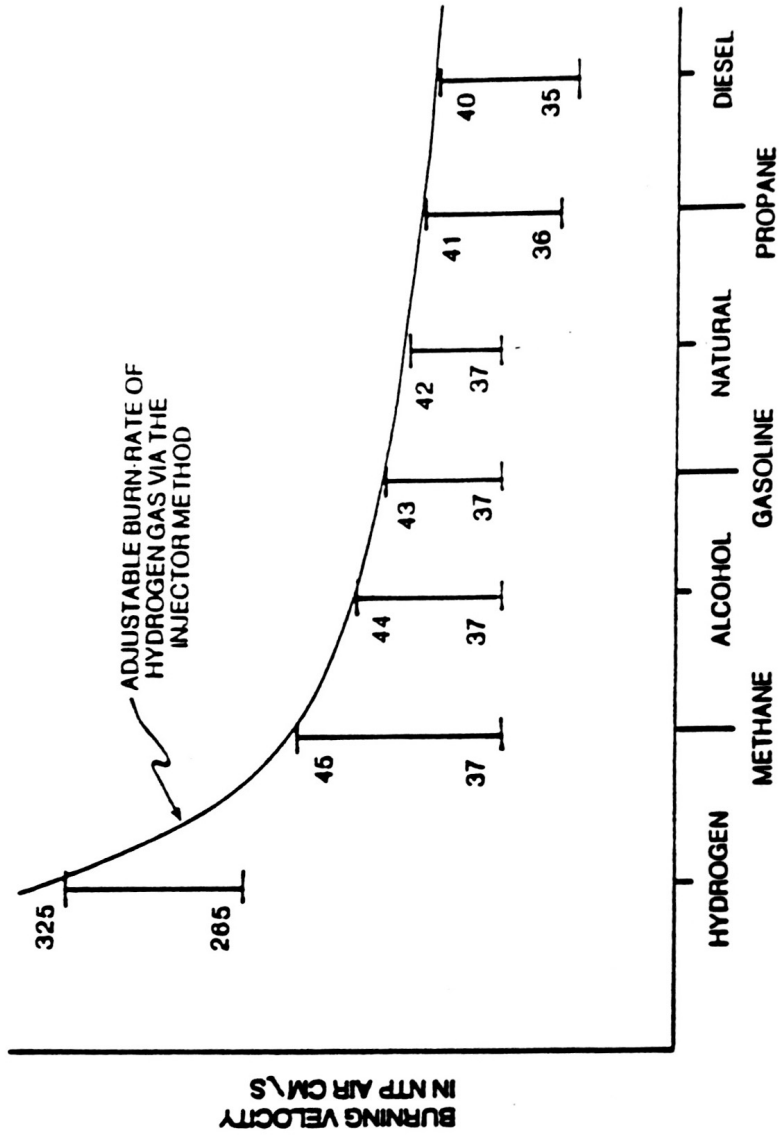

FIG. 23: TYPES OF LAND VEHICLE FUELS

Copyright © 1981 by Stanley A. Meyer

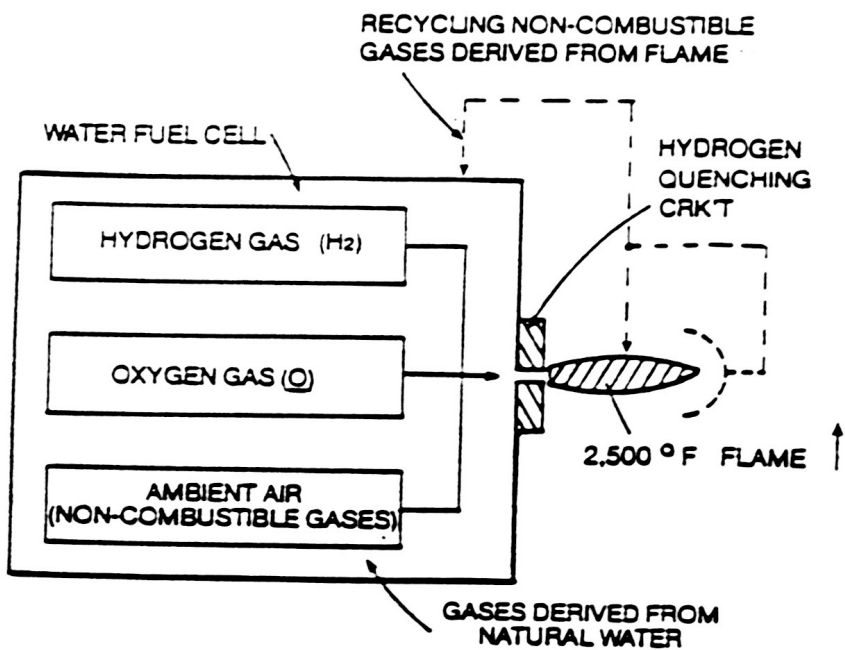

FIG. 24: RENDERING HYDROGEN SAFER THAN NATURAL GAS

Copyright © 1981 by Stanley A. Meyer

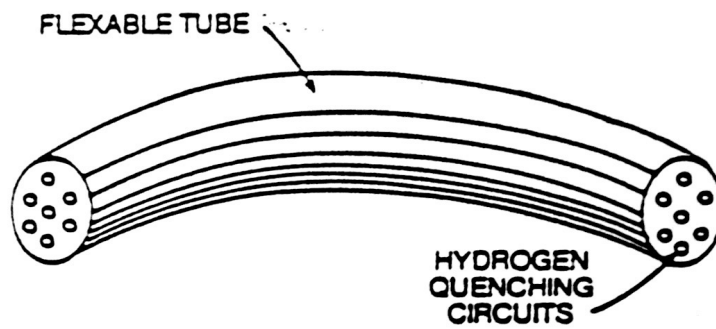

FIG. 25: QUENCHING TUBE ALLOWS THE HYDROGEN TO BE DISTRIBUTED WITHOUT SPARK-IGNITION

Copyright © 1981 by Stanley A. Meyer

collected again for hydrogen gas reuse. Of course, this recycling method is not as efficient as the hydrogen gas reclaim system of Figure 39, and so, illustrated in Figure A.

QUENCHING TUBE: DISTRIBUTING HYDROGEN SAFELY

To transport hydrogen gas from the Water Fuel Cell without spark ignition, the quencher circuit is carried one step further. Transportation of hydrogen is done, without regard for distance, through the "quenching tube;" see Figure 25. As the hydrogen passes through the tube, ignition cannot occur because it is impossible for the hydrogen, oxygen, and non-combustible gases to unite within the small confines of what is essentially an elongated quenching circuit. Gas pressure is not a factor either. If the gas pressure from the Fuel Cell decreases or is somehow shut off, the hydrogen still cannot retrace its path with the oxygen to unite for combustion.

FUEL CELL MEETS SAFETY REQUIREMENTS

The Fuel Cell is basically a composite of many systems integrated into a functional system. The system is one of constant demand that stores hydrogen in water until used. Water is the safest storage medium known to man. The hydrogen burn rate is adjusted to co-equal that of fossil fuels by using the quencing circuit and recycling of non-combustible gases back into the system. This allows hydrogen gas to be used in place of natural gas. The hydrogen gas can be transported without spark ignition, thanks to the quencing tube. The burning of the hydrogen gas is rendered clean by the catalytic process.

And finally, hydrogen recycling is performed for energy reuse. These integrated features give the Fuel Cell the ability to comply with and supersede any and all federal, state, and local housing and/or highway safety regulations.

8

Dynamic Ways To Produce Electricity

WATER, THE SOURCE FOR ELECTRICITY

The previous sections have outlined how hydrogen may be safely, easily and economically extracted from natural water. Not only that, the previous pages have shown how hydrogen may be harnessed for use as a free and abundant fuel source. Also, it has been shown how the hydrogen may support a flame in excess of 2,500 degrees Fahrenheit to supply thermal energy. But, in practical terms, how can this hydrogen energy from natural water be used to create electricity for use in factories, homes and businesses? This may be done in several ways.

LIMITS PLACED ON CONVENTIONAL POWER SYSTEMS

Currently, there are several ways to use high temperature flames to produce electrical energy. First, high temperatures may be used to power gas-actuated electrical generators. The high flame heats the gas, which becomes the driving force to power the generator, which in turn creates the electricity for use. Similarly, heat may be used to create steam to drive generators for electrical production.

Or, the hydrogen burn rate may be adjusted to co-equal the burn rate of fossil fuels (as previously described) to operate a gas-driven (internal combustion engine) electrical generator. The gas-driven engine not only provides mechanical energy to turn the electrical

generator, but also manufactures the exhaust gases needed to process the hydrogen gas on demand. This feedback technique is extremely good since the gas engine requires no special cooling apparatus nor the use of special high temperature alloys or materials for construction.

What does this mean for the consumer? Remembering that hydrogen by atomic weight is more than two and a half times more powerful than gasoline (NASA test data), and that 2/3rds of a water molecule contains hydrogen, not more than six gallons of water is needed to heat or cool an average 2,000 square foot home (rated at 135,000 B.T.U.s per degree day) in a 24-hour period. Several additional gallons of water are all that is needed to provide home electricity during the same time period. Also, a few gallons of water is all that is needed to run a typical passenger car in excess of 55 miles per hour.

All the systems may utilize the hydrogen by adjusting the burn-rate downward without sacrificing power yield. All systems have the capability to recycle hydrogen back into the form of water for energy reuse. See Figure A.

All of the above gas-driven systems are efficient and adequate, and all have common characteristics. They all have mechanical displacement parts that result in component wear during application. This may lead to higher operating costs because the lifespan of some mechanical parts may be limited. In order to provide an even more efficient and reliable energy system that complies with the laws of economics (the person with the least expensive way will be successful. Meyer has discovered how to create electrical energy without the need for moving mechanical parts.

THE BIRTH OF NEW TECHNOLOGY: THE EPG SYSTEMS

Meyer has done this by developing the "Electrical Particle Generator" (EPG system). He contemplated the idea of how to create a device with no mechanical moving parts that could produce electrical energy in all applications.

In order to do this, he knew he had to solve a multiplicity of problems. He needed to develop a system that conformed to his development specifications for the Fuel Cell. These specifications would allow the device to be constructed easily and economically, without the aid of hi-tech manufacturing techniques. He also knew he must make the system reliable, durable and efficient. He knew he also had to overcome the opposing magnetic field problem that requires high torque (rotational force) power input to operate conventional rotary electrical generators.

EPG: PRINCIPLES OF OPERABILITY

He accomplished the task with the Electrical Particle Generator by moving permanently magnetized gas through a non-magnetic, closed looped, tabular system; see Figure 26. As it moves, this magnetically charged gas traverses a pickup coil, which generates electrical energy. This process satisfies the law of physics that states that a magnetic field must pass through a coil of wire for the production of electricity.

Now, the permanently magnetized gas (which actually may be a fluid medium or semi-solid slurry) passes through the closed looped system without interruption. The energy input into the electrical particle

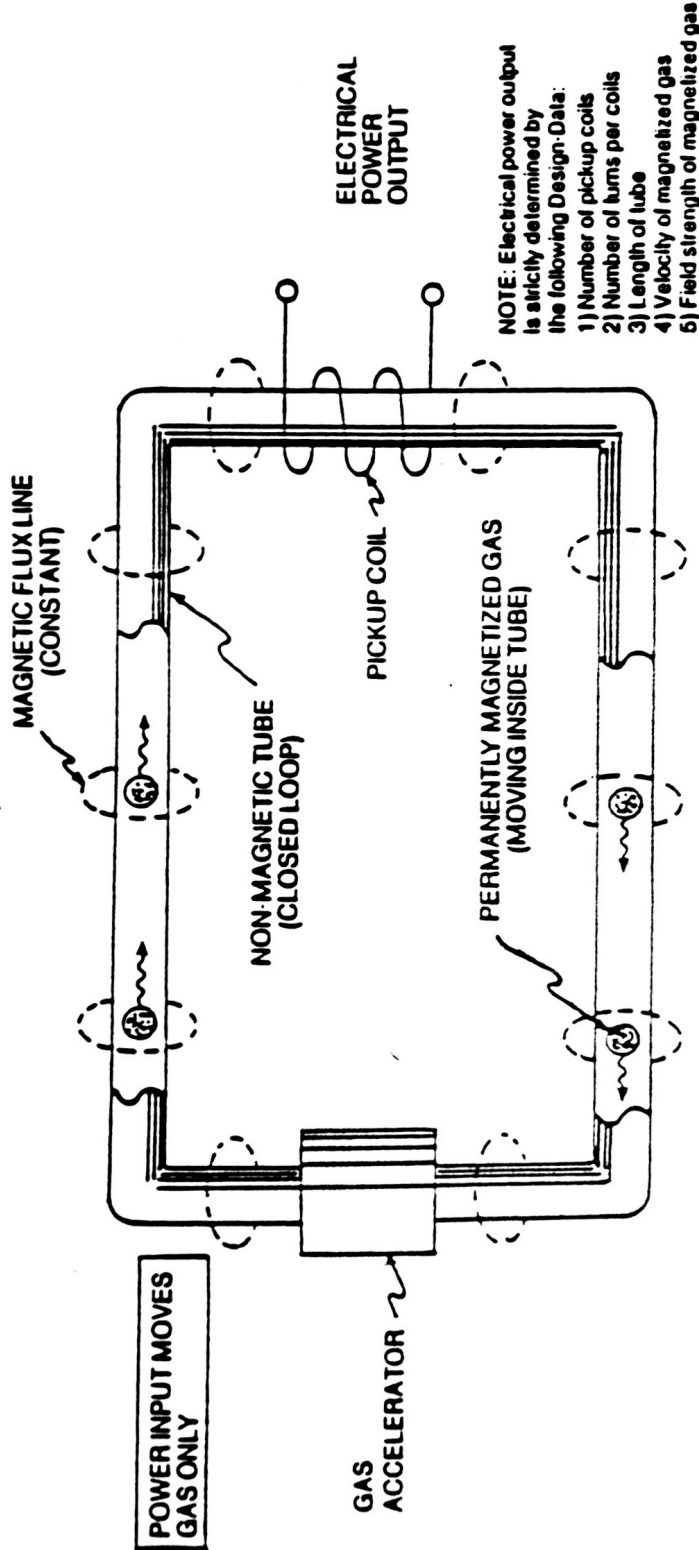

FIG. 26: EPG PRINCIPLE: ALLOWING A PERMANENTLY MAGNETIZED FLUID-MEDIUM TO PASS THROUGH A PICKUP COIL

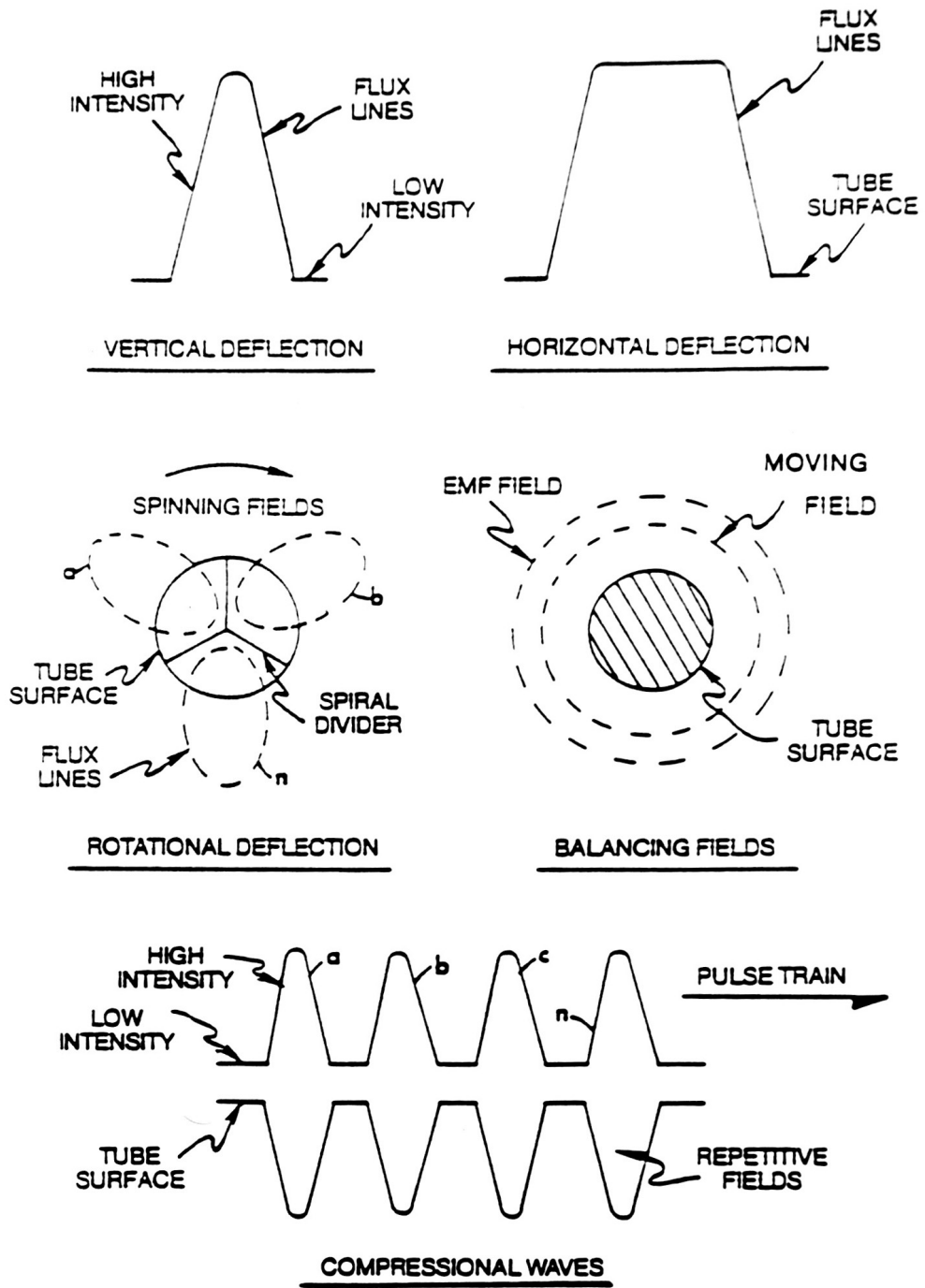
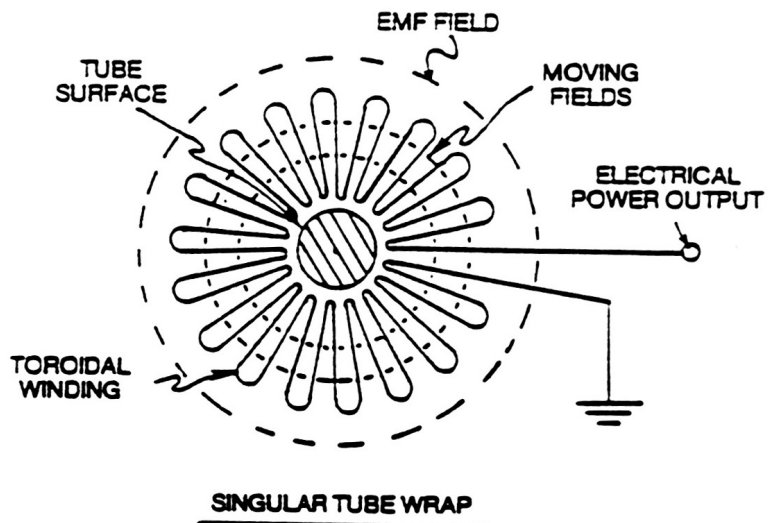
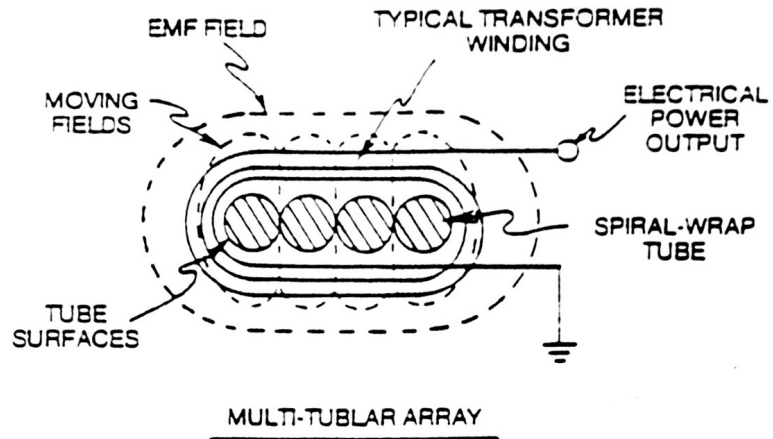

FIG. 26A: ATTENUATING GAS-FIELD

COPYRIGHT © 1981 BY STANLEY A. MEYER



**FIG. 26B: PICKUP COIL CONFIGURATIONS
(CROSS SECTIONAL VIEW)**

COPYRIGHT © 1981 BY STANLEY A. MEYER

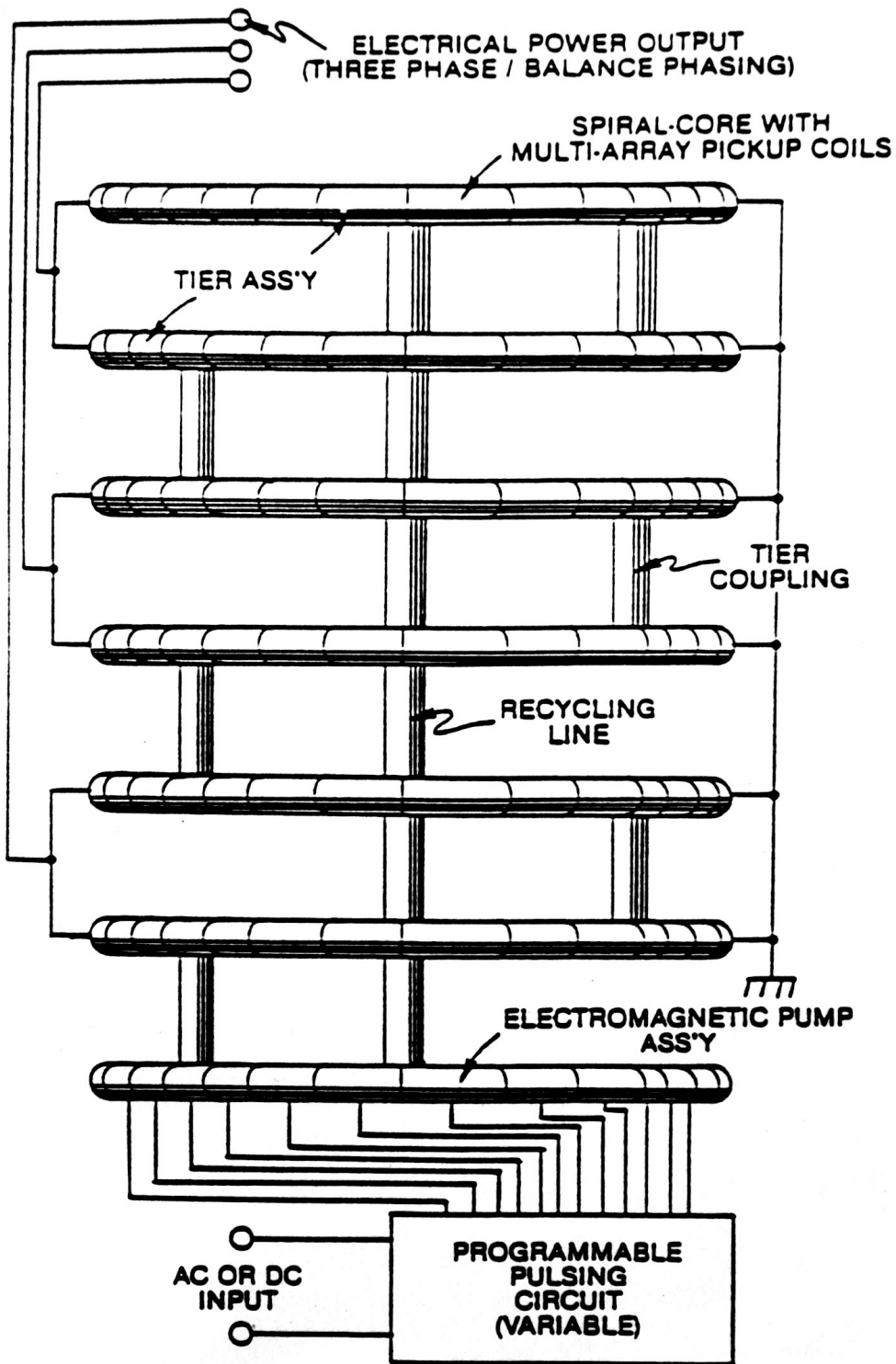

FIG. 26C: MULTI-TIER EPG ELECTRICAL GENERATOR

COPYRIGHT © 1981 BY STANLEY A. MEYER

generator is to move the gas, not to create the magnetic field of the gas. Since the moving gas field is attenuated to minimize the opposing emf fields of the pickup coils, very little input energy is required to move the magnetized gas. Power output from the electrical particle generator is simply determined by the coil-wrap of the tube through a given number of coils.

EPG: MECHANICAL DRIVE SYSTEM

Only a few pounds of pressure is needed to drive the magnetically charged gas through the system. This may be done mechanically by a small, non-magnetic turbine wheel powered by a small AC or DC electric motor; see Figure 27; or powered by hydraulics, steam, wind power, or even manpower. But again, moving parts wear out, so this is the least desirable method of moving the gas through the system, despite the fact input to output efficiency of the electrical particle generators exceeds the performance "specs" of typical rotary electrical generators.

EPG: ELECTROMAGNETIC DRIVE SYSTEM

Another way to move the magnetically charged gas through the closed looped system is the use of an Electromagnetic Pump Assembly, as shown in Figure 26C and 28. The multi-coil arrangement is pulsed in a way as to allow the electromagnetic field to "walk" in a linear motion. Since the walking fields lock onto the gas, the gas moves onward to and through the pickup coils and is recycled again for continuous power generation. Increasing pulsing rate increases gas velocity which, in turn, increases power output without system change.

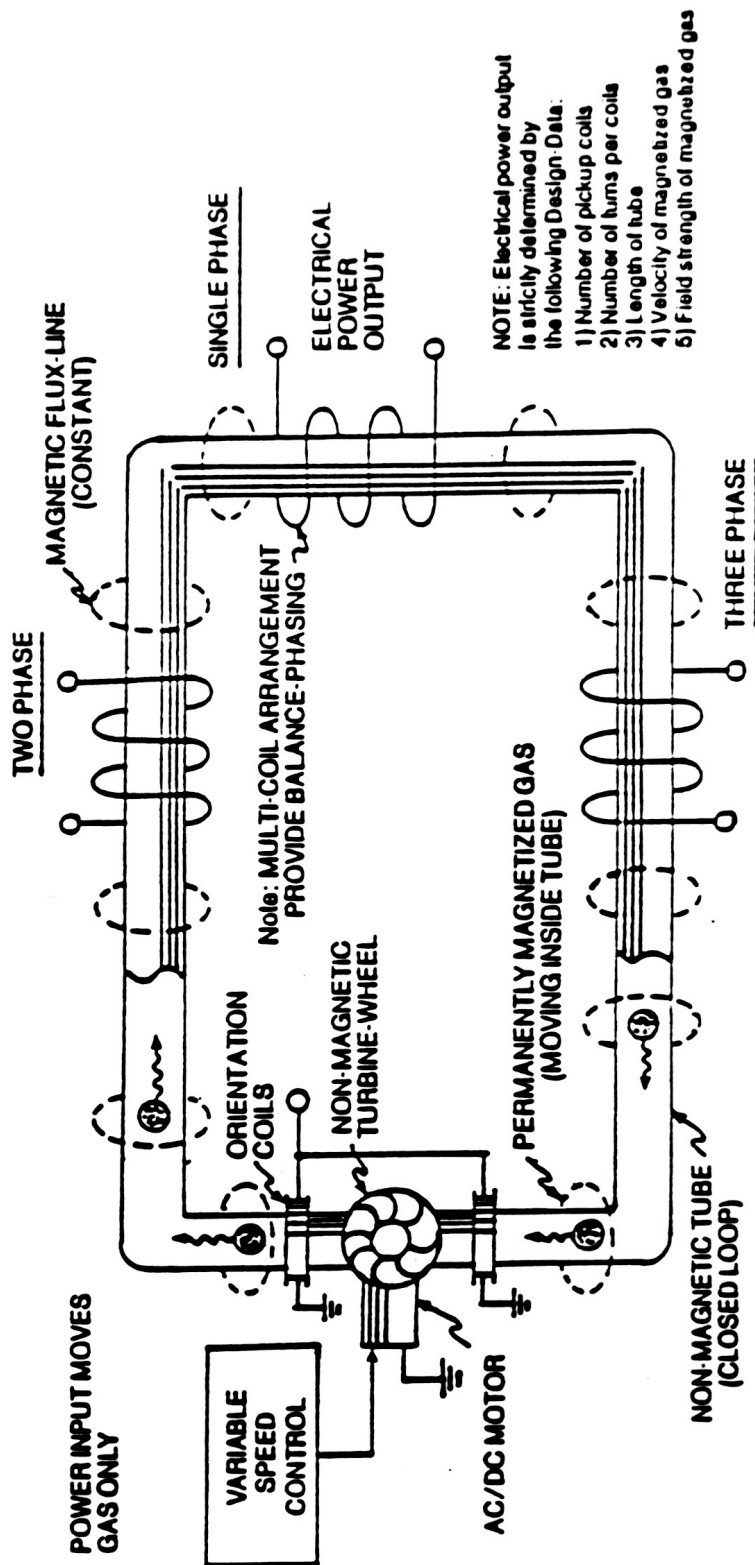

NOTE: Electrical power output is strictly determined by the following Design Data:

- 1) Number of pickup coils
- 2) Number of turns per coils
- 3) Length of tube
- 4) Velocity of magnetized gas
- 5) Field strength of magnetized gas

FIG. 27: EPG MECHANICAL DRIVE GAS ACCELERATOR

Copyright © 1981 by Stanley A. Meyer

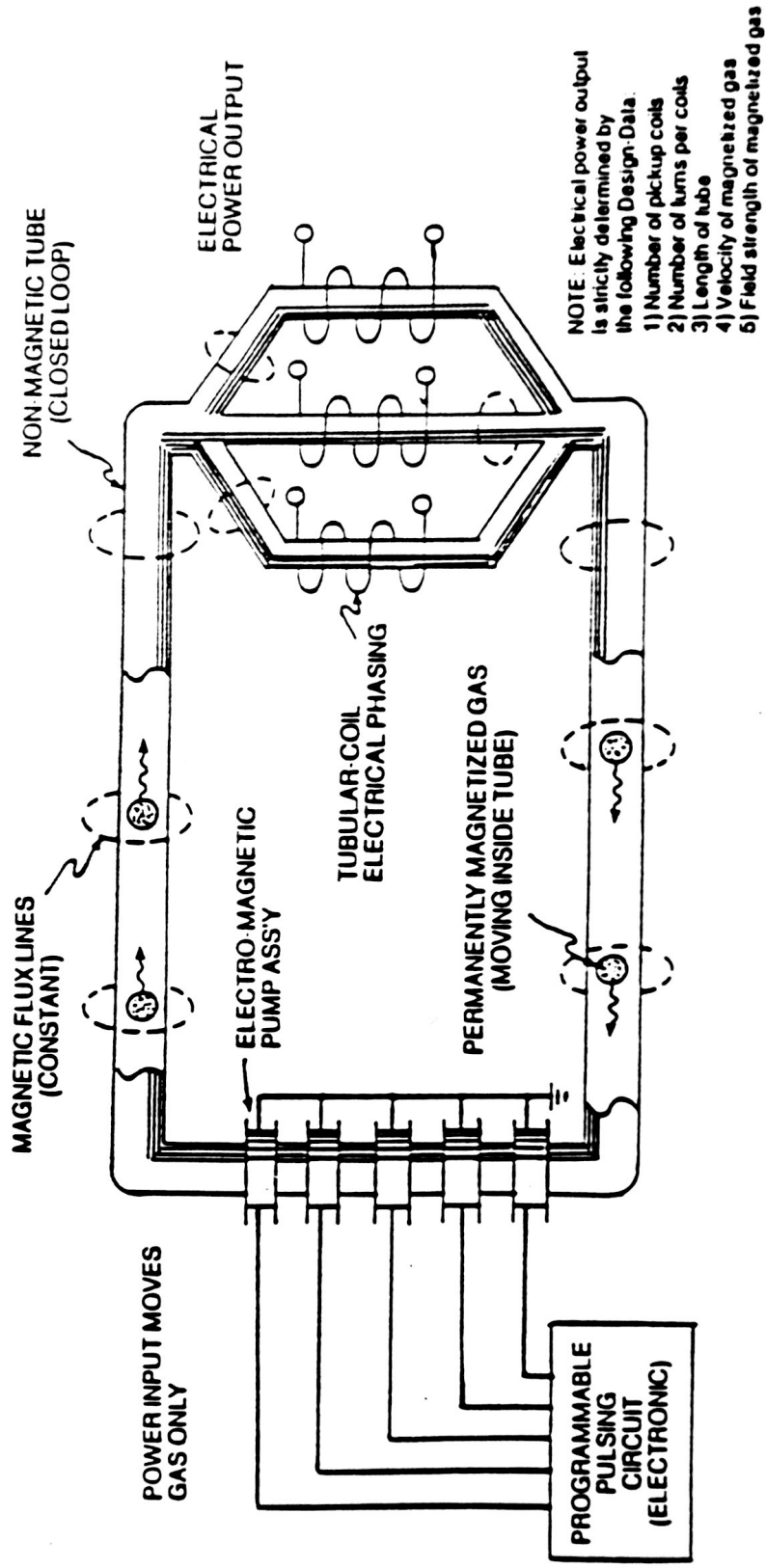

FIG. 28: EPG ELECTRICAL MAGNETIC GAS ACCELERATOR

EPG: PARTICLE BEAM ACCELERATORS

Finally, and most dynamic, is the use of a laser beam driven EPG system; see Figure 29. In this system, the permanently charged particles of gas are driven close to the speed of light through the closed looped system by the physical motion of the low power laser beam. In this application, the non-magnetic tube is used as a typical light-guide (reflective surface inside a hollow tube). In other applications, particle beam accelerators beyond the laser can be used for gas displacement...moving the gas-field for electrical power generation.

EPG: ATTENUATING GAS-FIELD

In each progression of the above cases, there is an increase in power output because the movement of the gas through the system is greater. In each case, low energy is required to move the gas through the tubular system. Because of the flexibility of the system design, it is the geometrical configuration of the system that determines power output. In all cases, power input deals with moving the gas...not creating an electromagnetic field for the gas. In all cases, the field of the gas can be attenuated in ways to overcome emf opposition: horizontal to vertical deflection, rotational, compressional wave, and/or field balancing between different magnetic fields, as shown in Figure 26A.

Any combination of these attenuated fields can be used simultaneously while moving the magnetized gas. To spin the moving gas along the longitudinal axis of the tube without mechanical

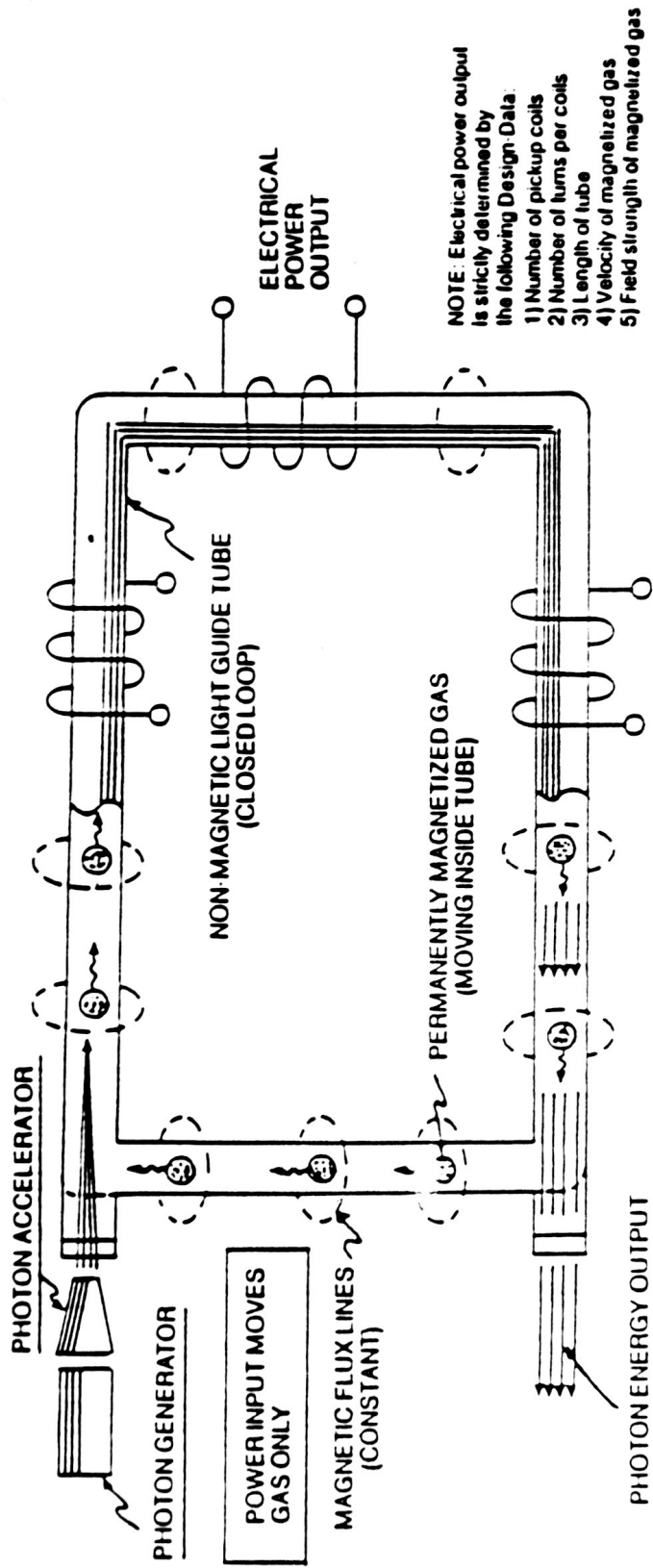

FIG. 29: EPG PHOTON DRIVE GAS ACCELERATOR

displacement, a multi-channel "spiral divider" (see Figure 26A) is inserted into the entire length of the tubular "pathway" (see Figure 33) beyond the gas accelerator stage, as illustrated in Figures 26 through 29.

The rotating gas-field can now be varied from a vertical to horizontal movement (magnetic field cycling) by disrupting the dyne-axis (particle alignment) of the permanently magnetized gas (see Figure 30) when orientation coils (see Figures 27, 37 and 38) are used. Pulsing the orientation coils slowly produces the horizontal movement of the gas-field, whereas a faster pulse rate creates a spike wave form. The pulsating magnetic fields of the orientation coils simply regulate the particle spin of the gas in a linear motion since "transformer action" cannot occur due to the permanently magnetized gas. A compressional wave form (Figure 26A) is now produced by superimposing a pulsating pressure onto the spinning gas.

Compounding action (clustering magnetic fields) of the wave forms occurs when the tubular "pathway" (see Figures 26B and 33) is spiraled through the pickup windings. And to help minimize wave form distortion, the emf field strength is preset (balancing the fields) as to power loading of pickup coils. These operational parameters help keep the gas velocity constant since the pulsating gas-field can be synchronized with the repetitive formation of the emf field. Of course, the oscillating magnetic fields (moving flux lines) transverse the coil windings for electrical power generation.

To cancel out magnetic field loss (magnetic flux lines not being used) during EPG operations, the "transformer" coil-wrap (Figure 26B)

is used with the tubular spiral-wrap configuration of Figure 23. The toroidal coil-wrap (also Figure 26B) is ideally suited for singular tube applications. Other coil-wrap designs can be used for particular electrical needs. In all cases, the pickup coils are placed end to end around the portion of the tube beyond the gas acceleration stage, as shown in Figures 26C, 27 through 29 and 33, to form a magnetic coupling of the emf fields emanating away from the moving gas-field; see Figure 26B again. These concentric magnetic rings allow a magnetic field to pass inside another magnetic field without opposing forces since all of the magnetic flux lines are parallel to each other.

EPG: FLEXIBILITY OF POWER YIELD

The EPG electrical power output is design-variable since the electrical generators can take on different sizes to meet a given power need. If additional electrical power is required, simply increase the number of pickup coils. If more amps are needed, connect the pickup coils in parallel. If higher voltage is desired, connect the pickup coils in series arrangement. If a given electrical power yield is contemplated, connect the pickup coils in a series/parallel arrangement to meet the electrical need. Multi-phasing is simply accomplished by subdividing the coil network to provide proper electrical hookup. Balance phasing is automatic since the gas velocity remains constant while passing through the entire array of pickup coils.

Pulse phasing of the electrical power output is accomplished by pre-arranging the pickup coils within an array. D.C. pulses occur when the coil arrays are of like turns. A.C. pulses are produced when

pickup coils are directly linked to oppositely turned coils of similar design. AC/DC output occurs when both types of coil arrays are wrapped around the same tubular structure in a singular or multi-tier arrangement as shown in Figures 26C and 33.

And finally, to vary electrical power output without system change, simply vary gas velocity. To vary pulse rate output, vary the pulse rate input to the orientation coils.

EPG: MAGNETIC SPIN GENERATOR

As an alternative to the moving gas approach, the EPG magnetic field spin generator simply rotates the permanently magnetized gas on its dyne-axis by pulsing orientational coils, as shown in Figure 30.

The variable pulse voltage frequency input directly determines the power output of the spin generator. Again, the power input into the spin generator is used to reorientate the permanently magnetized gas, not to produce the magnetic field of the gas.

EPG: OPERATIONAL PARAMETERS

Regardless of the type of EPG electrical generator, the electrical power output is determined by one, or several, or all of the following design parameters: 1) field strength of gas or particle under pressure; 2) gas velocity; 3) number of turns per coil; 4) number of coils; 5) number of tubular wraps per tier (see Figure 33); 6) magnetic field spin (horizontal to vertical deflection, rotational, and compressional wave; and 7) any and all combinations of the above.

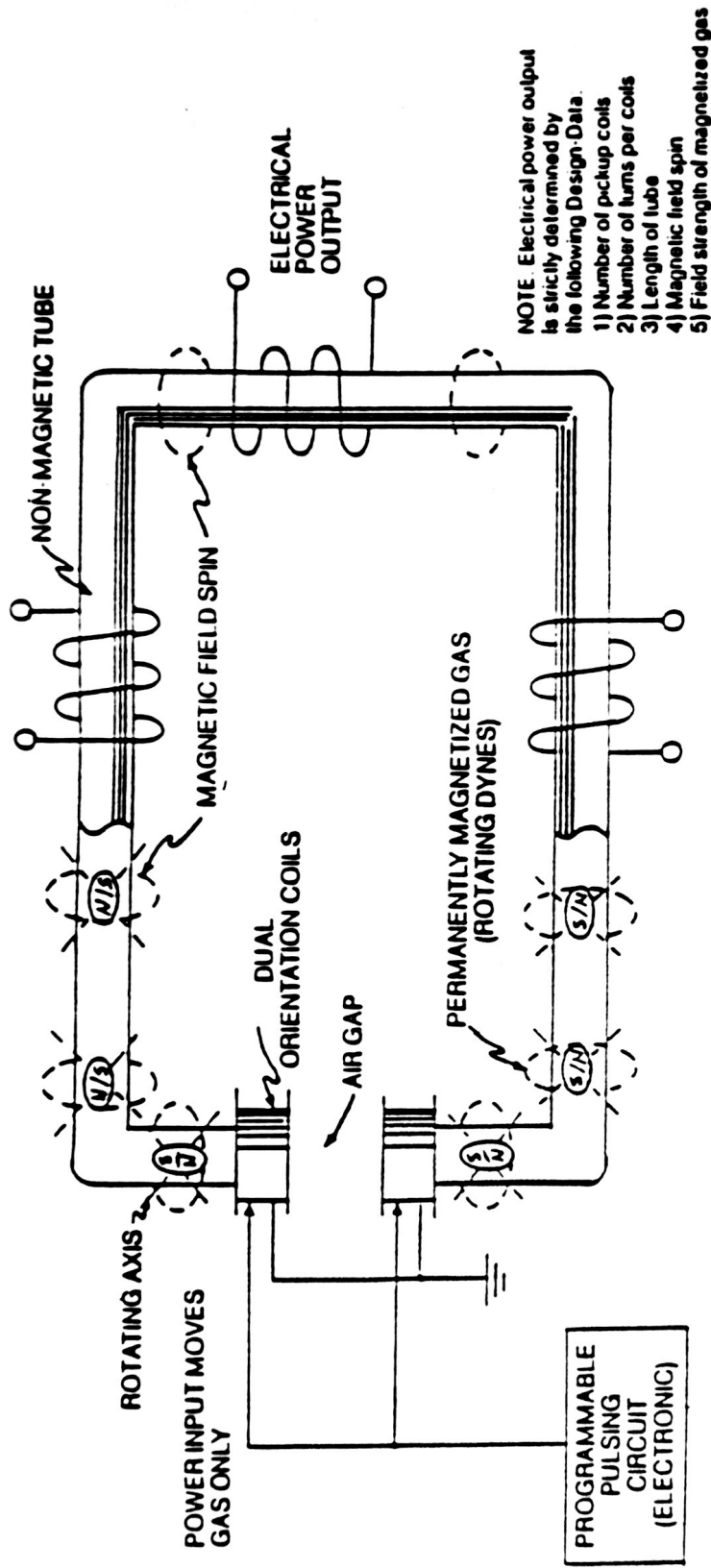

FIG. 30: EPG MAGNETIC FIELD SPIN GENERATOR

Copyright © 1982 by Stanley A. Meyer

The only purpose of the power input into the EPG electrical system is to move, rotate, cycle, and/or attenuate the magnetic field of the magnetically charged particle-gas under pressure.

By climatizing the EPG system into a water tight, pressure tight housing, the EPG system can be used on land, under the sea, or in the vacuum of space. Gravitational forces have no appreciable effect on the operational performance of the EPG generator since the portable power unit is a closed loop system.

FUEL CELL LINKED TO EPG SYSTEMS

Just as important, the fuel cell can be used to produce electrical energy in several different ways, as illustrated in the energy-grid system of Figure A and pictorially shown in water fuel cell of Figure B. The "Q" pipe (or heat pipe) assembly simply transfers heat energy from the sustained hydrogen flame to the thermal gas pump of Figure 38 without any mechanical moving parts. The quenching tube distributes the processed hydrogen gas to the gas-engine of Figure 37 without the aid of a gas pump. The gas flow pressure from the fuel cell turns the dual-turbine assembly of Figure 36 without altering the combustion property of the gas. Finally, and most dynamic, the electrically charged atoms of Figure 20B are used in conjunction with the electrical polarization generator of Figure 40 prior to gas ignition.

Whenever a gas powered electrical unit is connected to the EPG network of Figure A, the electrical system hookup is known as a regenerative energy feedback module, as illustrated in Figure B.

9

Spin Off Technology

In almost all cases of scientific accomplishments, spin-off technology occurs. The Water Fuel Cell is no exception. For every cause there is a reason and for every reason there is an answer and for every answer there is progress. Without scientific progress, we cannot hope to cope with, nor solve, the energy needs of the world. The areas of development below are for that purpose and that purpose only.

TRANSMITTING HYDROGEN THROUGH CONVENTIONAL GAS LINES

In the area of hydrogen distribution, the quenching circuit technology (see Figure 24) can be altered in a way as to allow hydrogen gas to be transmitted through a standard gas line safer than natural gas, as so illustrated in Figure 31. This is accomplished in a three-step process. First, the ambient air is converted into non-combustible gases (non-burnable gases having no oxygen atoms) when exposed to an open flame. Secondly, the non-combustible gases are systematically mixed with the hydrogen gas to adjust the hydrogen burn rate to co-equal that of natural gas (see Figure 23). Thirdly, the hydrogen flame is sustained and maintained since the non-combustible gases act as a modulator that retards the speed at which the oxygen atoms (obtained from ambient air) unite with the hydrogen atoms during the combustion process.

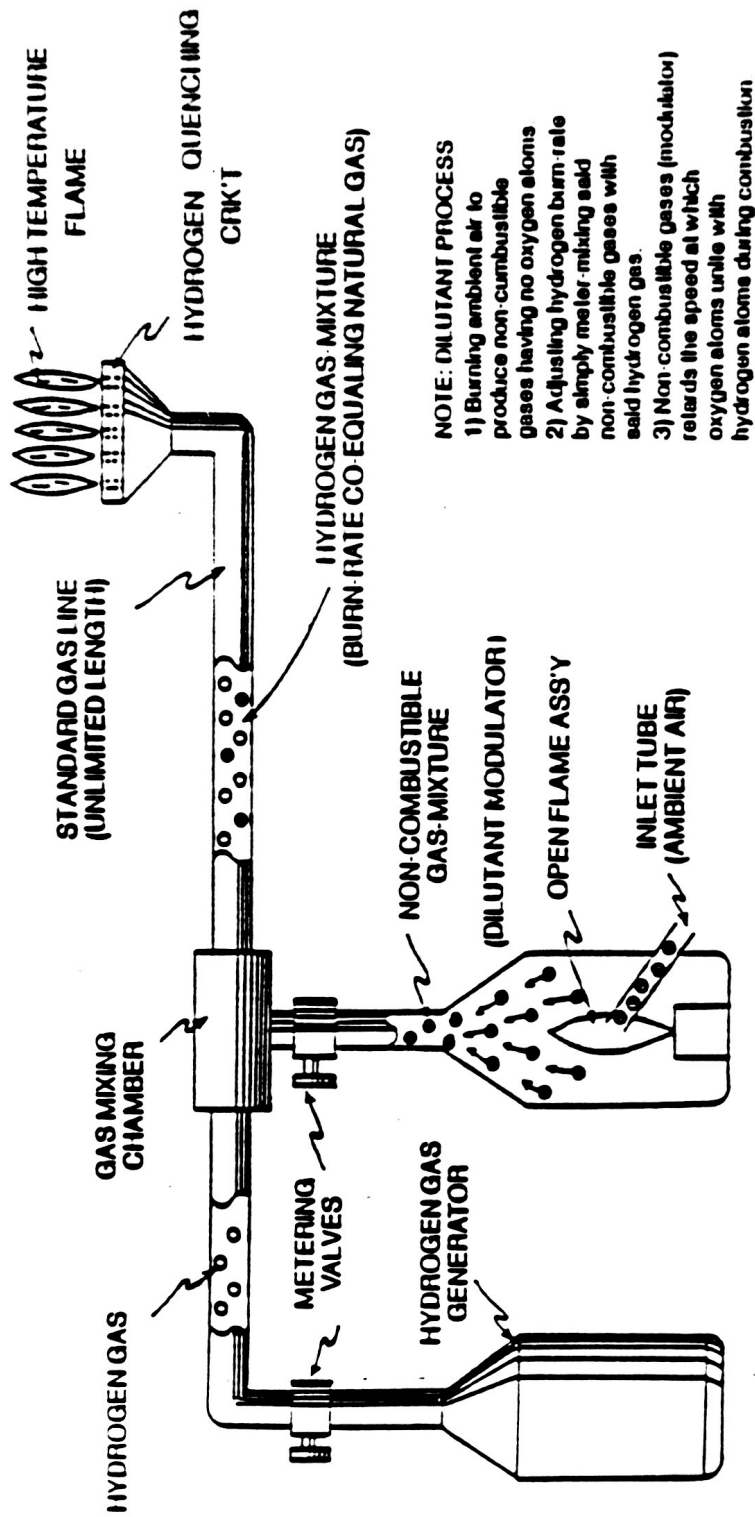

NOTE: DILUTANT PROCESS

- 1) Burning ambient air to produce non-combustible gases having no oxygen atoms
- 2) Adjusting hydrogen burn-rate by simply meter mixing said non-combustible gases with said hydrogen gas.
- 3) Non-combustible gases (modulator) retards the speed at which oxygen atoms unite with hydrogen atoms during combustion

FIG. 31: UTILIZING STANDARD GAS LINE TO TRANSPORT HYDROGEN GAS SAFER THAN NATURAL GAS

Copyright © 1980 by Stanley A. Meyer

Economically, the air conversion cost is almost negligible when considering the fact that a small open flame can convert billions of cubic feet of ambient air (which is free) into non-combustible gases...and especially when the Water Fuel Cell can provide both the open flame as well as the hydrogen gas. The processed hydrogen gas mixture requires no special handling requirements and can be injected into a conventional gas grid system without the aid of special connectors or other hardware.

STEAM RESONATOR

In the realm of steam power, the resonant cavity technique (see Figures 12, 17, 19 and 20) can be combined with the electrical charging of a single atom (one type) of a water molecule to produce superheated steam on demand, as shown in Figure 32. As the incoming water molecule is exposed to the positive (b+) electrical voltage zone forming the resonant cavity vessel, the hydrogen atoms become positive (b+) electrically charged.

Since like charges repel and cause motion, the accelerated electrically charged molecule (b+ only) collides with the other water molecules, producing heat which is absorbed by the surrounding water. Repetitive formation of the positive (b+) electrical voltage zones (see Figures 9A, 9B and 16) causes instant steam without consuming power in the form of amps. To further increase steam yield, simply increase the amplitude of the applied pulse voltage frequency potential of a single polarity.

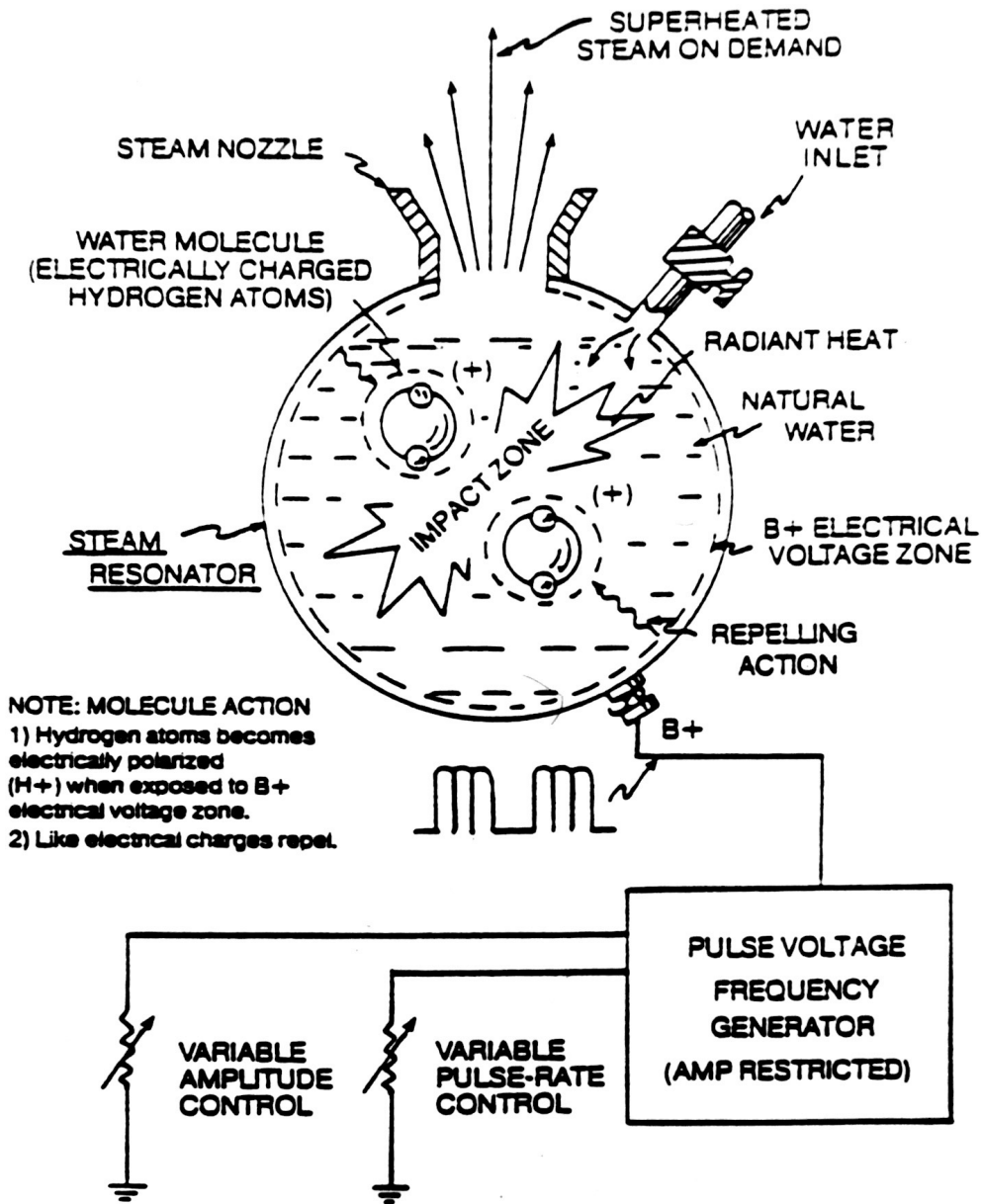

FIG. 32: UTILIZING VOLTAGE POTENTIAL TO PRODUCE SUPERHEATED STEAM ON DEMAND

Linked with the EPG systems (Figures 26 through 30), or with the pulse voltage frequency generators shown in Figures 33 and 34, the steam resonator (Figure 32) can be directly retrofitted to any size power plant using steam as power. No fossil fuels or other burnable additives are needed in the process.

HIGH FREQUENCY PULSING GENERATOR

In special areas of power applications, the non-mechanical pulse voltage frequency generator (See Figure 33) can be utilized where ultra high pulse frequency is needed without sacrificing power yield. The multi-array primary coils overcome the pulsing limitation of a single coil; whereas the spiral transformer core (hollow structure) reduces the magnetic field loss between the primary and secondary windings. The multi-tier arrangement allows for multi-power applications.

To help maximize power loading efficiency, the spiral tubular core configuration (Figure 33) is also incorporated into the design of the EPG electrical system (Figures 26 through 30). The spiral core configuration is also instrumental in providing balance phasing between any given number of pickup windings.

ELECTRICAL PULSE GENERATOR

To further facilitate flexibility, the Electrical Pulse Generator (Figure 34) was primarily developed for special applications, such as for grain drying or for regenerative energy feedback systems. The rotating first and second stage pickup coils allow the magnetic field

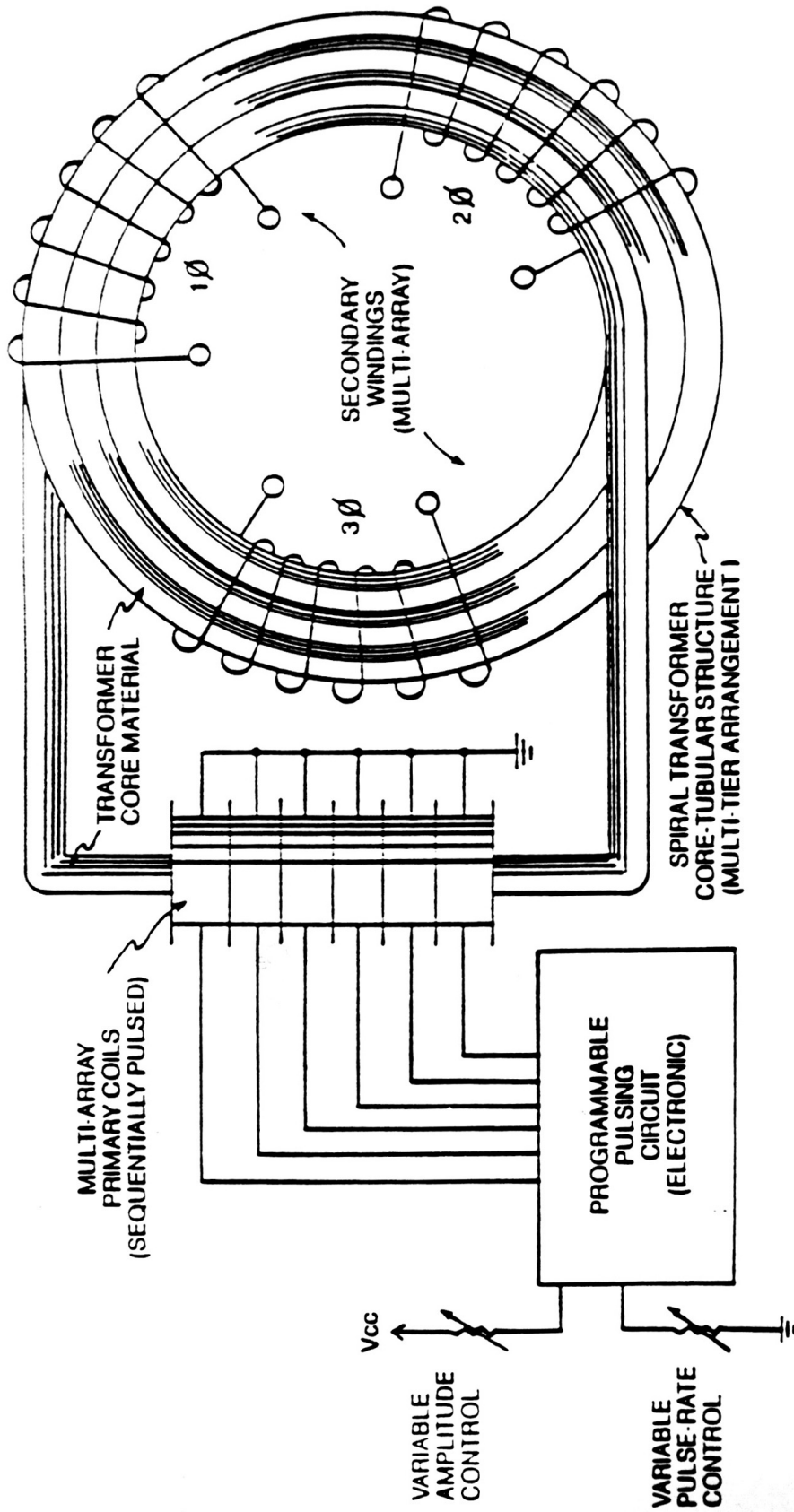
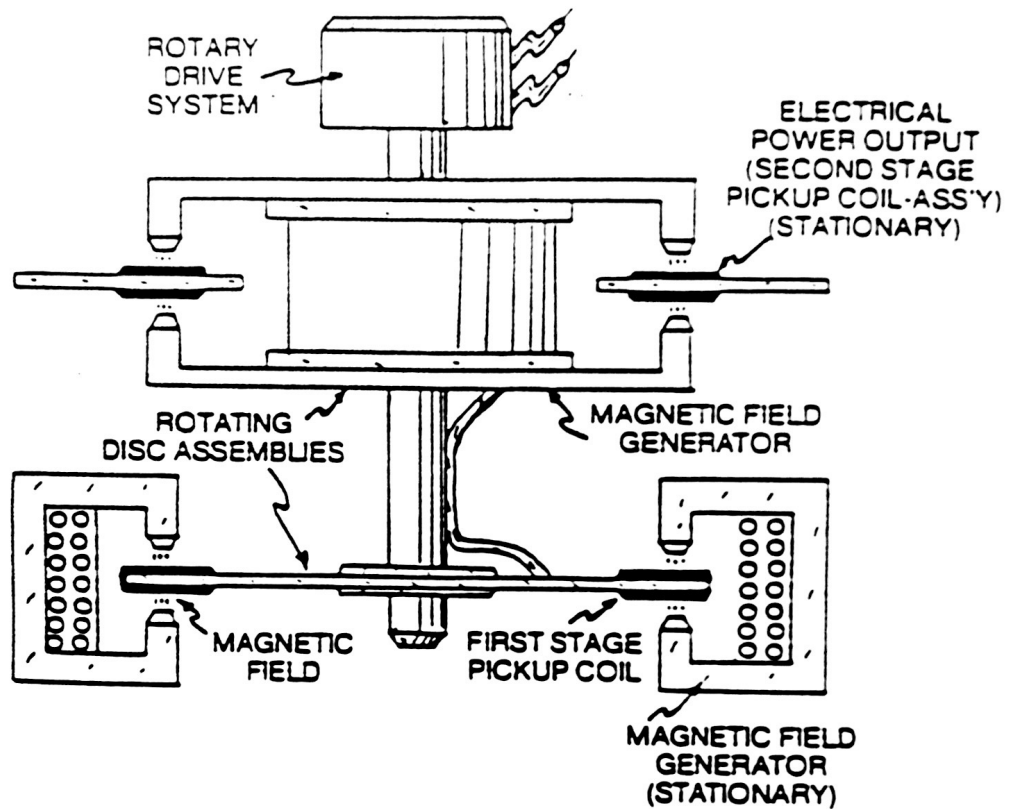

FIG. 33: ULTRA HIGH UNIPOLAR PULSE VOLTAGE FREQUENCY GENERATOR (NON-MECHANICAL)



**FIG.34: ROTARY PULSE VOLTAGE
FREQUENCY GENERATOR**

COPYRIGHT © 1983 BY STANLEY A. MEYER

strength of the first magnetic field circuit to be increased in the second magnetic circuit...increasing power output without the aid of contact brushes.

LIGHT GUIDE LENS ASSEMBLY

Solar energy input into the energy grid system (Figure A) can be obtained by utilizing a Light Guide Lens Assembly, as shown in Figure 35. The cylindrical "wall" lens, focusing and transfer lenses, and capping lens form a unitized silo structure that collects, redirects, transfers and focuses the light energy without any moving parts, regardless of the sun position during the daylight hours or seasons. The concentrated solar energy can either be stored or converted into electrical energy by high-yield solar cells. The solar lens operates on the fiberoptic principle.

GAS DRIVEN ELECTRICAL PARTICLE GENERATOR

Combining the Water Fuel Cell with the Electrical Particle Generator, as shown in Figure 36, further aids the energy grid system (Figure A) as to energy feedback by coupling a dual turbine wheel assembly to the quenching nozzle of the Fuel Cell. As the gas is generated and expelled through the gas nozzle, the moving gas turns the first stage turbine, which drives the second stage turbine that propels the magnetized gas for electrical power generation. This process does not convert the generated gases in any way...it only utilizes the pressure of the gas to perform work during Fuel Cell operations.

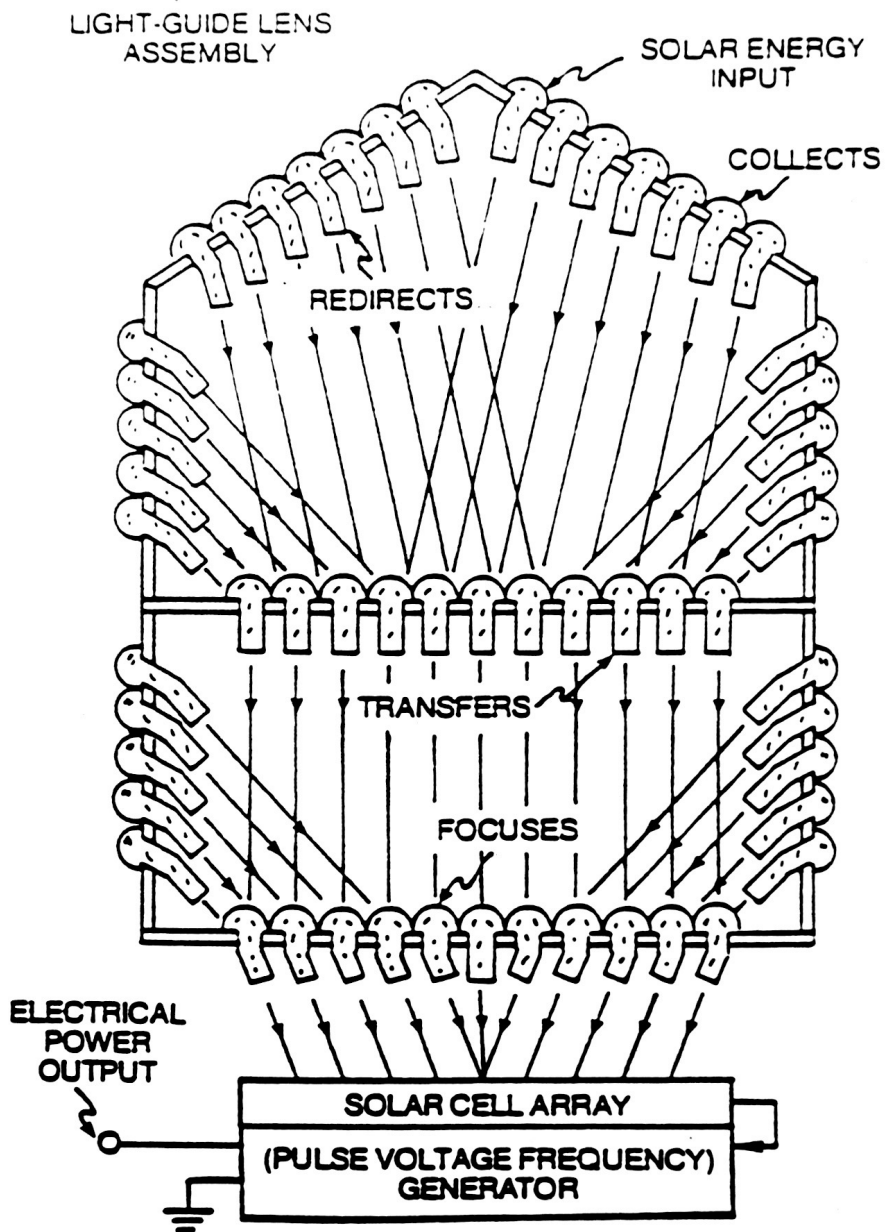

FIG.35: SOLAR ELECTRICAL POWER GENERATION SYSTEM

COPYRIGHT © 1981 BY STANLEY A. MEYER

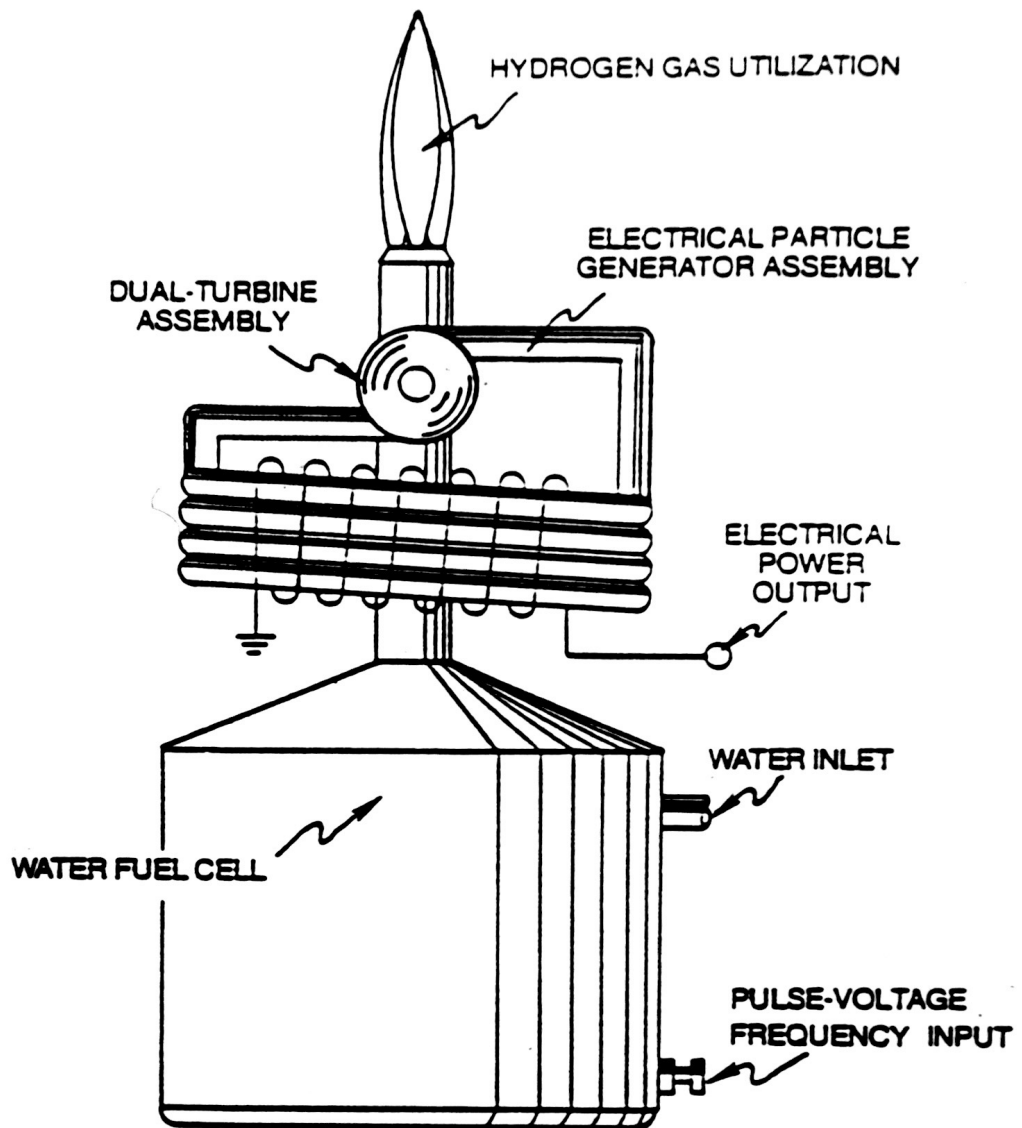

FIG.36: GAS DRIVEN ELECTRICAL GENERATOR

COPYRIGHT © 1982 BY STANLEY A. MEYER

INTERNAL COMBUSTION ELECTRICAL GENERATOR

Another regenerative energy feedback network is formed when the Electrical Particle Generator of Figure 37 is retrofitted to any type of internal combustion engine. The engine mechanical drive train is affixed to the EPG turbine that propels the magnetized gas for electrical power generation. Since the hydrogen gas burn rate equals gasoline, the engine gas-fuel is directly supplied by the Fuel Cell in Figure A. This process simply utilizes the combustion property of hydrogen gas rather than the movement of the gas.

THERMAL PUMP ELECTRICAL GENERATOR

The Thermal Pump Electrical Particle Generator of Figure 38 operates on the third aspect of the hydrogen gas, which is heat. The sustained hydrogen gas flame of Figure A provides the heat energy input to drive the thermal pump assembly, which in turn provides torque power to the EPG turbine assembly

Beyond the gas conversion process, the EPG turbine assembly can be affixed to portable windmills or compressed air systems for EPG operations.

ELECTRICAL POLARIZATION GENERATOR

To complete regenerative energy grid of Figure A as to Water Fuel Cell of Figure 8, the electrical polarization generator of Figure 40 is utilized to capitalize on the fourth aspect of a gas, which is gas ionization.

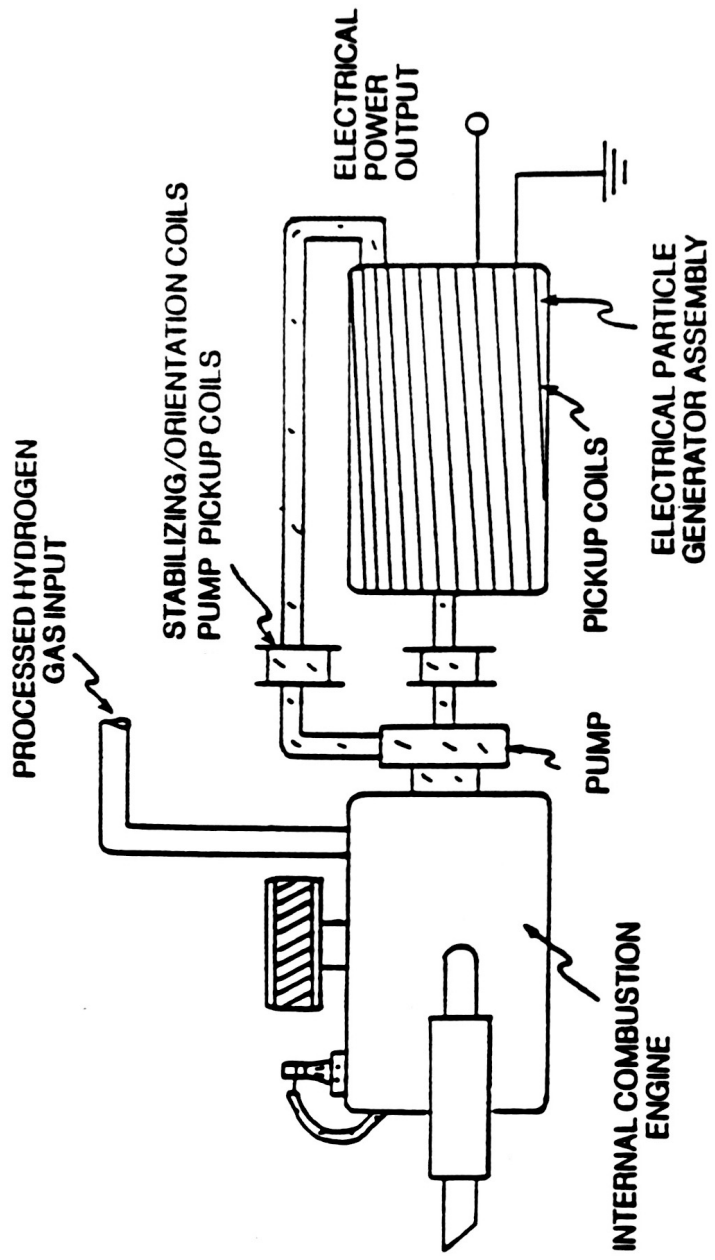

FIG. 37: INTERNAL COMBUSTION ELECTRICAL GENERATOR

COPYRIGHT • 1982 BY STANLEY A. MEYER

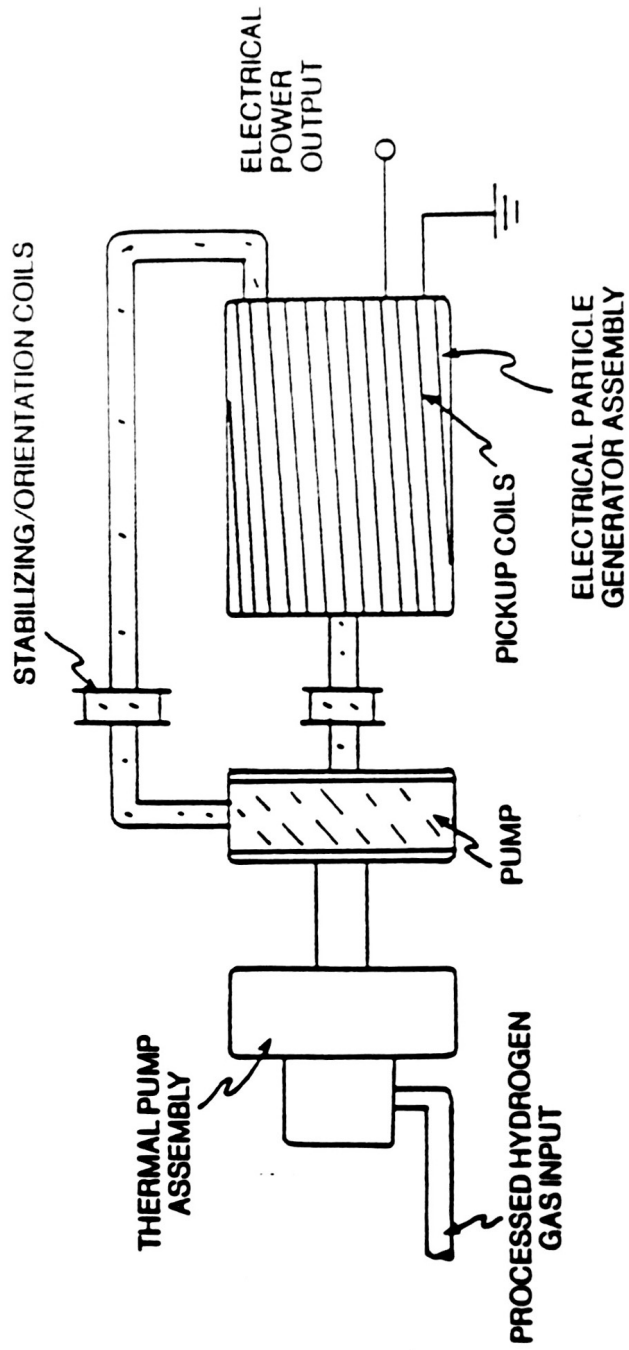
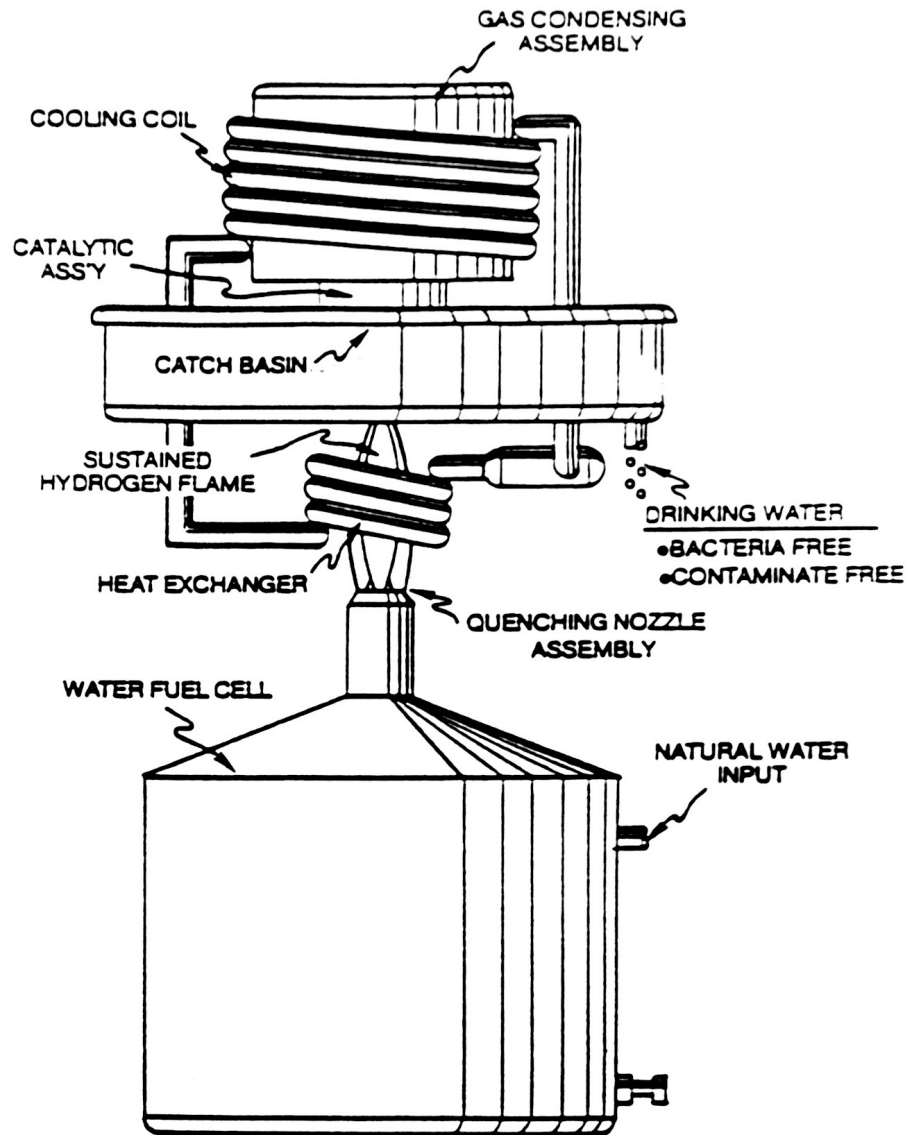

FIG. 38: THERMAL PUMP ELECTRICAL GENERATOR

COPYRIGHT • 1982 BY STANLEY A MEYER



**FIG 39: HYDROGEN GAS RECLAIM SYSTEM
(WATER PURIFICATION)**

COPYRIGHT 1983 © BY STANLEY A. MEYER

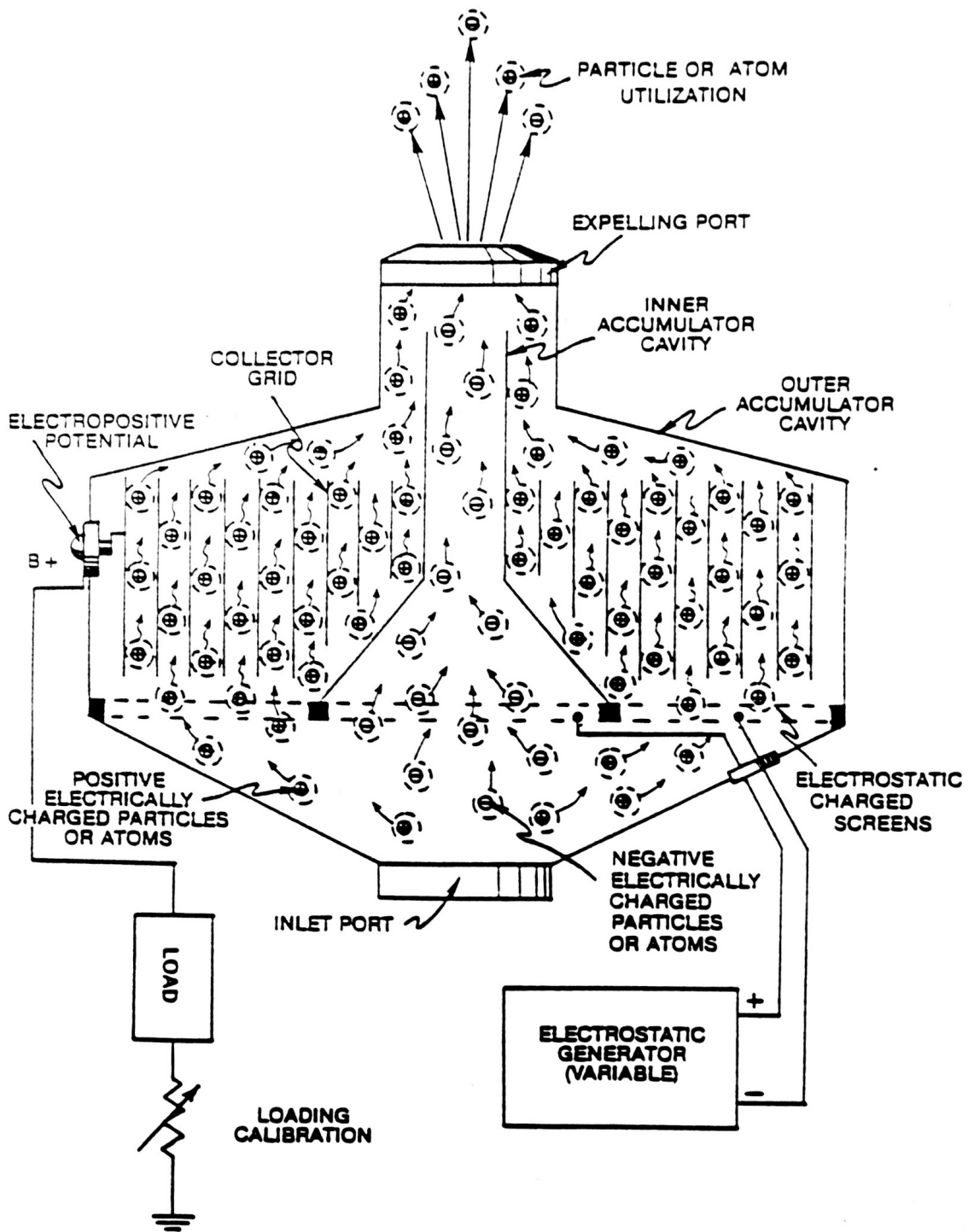

FIG. 40: ELECTRICAL POLARIZATION GENERATOR

COPYRIGHT © 1983 BY STANLEY A. MEYER

As illustrated, a stream or group of positive electrically charged atoms on a surface causes the collector-grid surface to be positive charged, which in turn makes the terminal post positive charged since said terminal post is affixed to said collector-grid. As more charged atoms are entrapped within said collector-grid, said terminal potential increases until gas flow rate becomes constant.

Once an electrical load is placed between said positive terminal post and electrical ground, an electric current performs work as to load capacity.

The electrostatic charged screens attract more charged atoms to continue the electrical performance of said generator. In essence, said electrical polarization generator (Figure 40) requires no chemical interaction nor moving parts since the moving electrons combined with the moving charged atoms prior to secondary atom utilization beyond the expelling ports.

If required, negative electrical potential is generated by allowing negative electrically charged atoms to pass through the inner accumulator cavity.

HYDROGEN GAS RECLAIM SYSTEM: WATER PURIFICATION

As explained in Section Six and as illustrated in Figure 39, the hydrogen gas reclaim system renders hydrogen environmentally safe. In actuality, the reclaim system is a water purification system that has the capability of extracting both contaminants and bacteria from

natural water without the aid of chemical additives or special filtration systems. The water purification process is quite simple: the electrical polarization process splits the water molecule to form a gas mixture that sustains a hydrogen flame during combustion and produces water vapor. Contaminants that are no longer stored between the splitting water molecule are systematically discarded from the Fuel Cell. If any bacteria in water affix themselves onto the expelling gas, the high temperature flame simply incinerates them. The catalytic block assembly ensures the complete combustion of the hydrogen gas, and the catch basin simply collects drinking water free of all contaminants, bacteria and chemical toxicity. This system is ideally suited for desalination of ocean water for desert irrigation. Mineral extraction from water is another application.

THE WATER FUEL CELL TECHNOLOGY ANSWERS THE QUESTION

The Water Fuel Cell technology is a composite of many systems integrated together for a common purpose...providing a practical answer to the energy problem. The hydrogen age can now replace the fossil fuel era.

SUBJECT TO COMPLETION
PRELIMINARY PROSPECTUS DATED JUNE 10, 1988

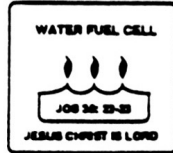

WATER FUEL CELL
3792 Broadway
Grove City, Ohio 43123
(614) 871-4173

WFC Profit Sharing Certificate

Prior to this offering, there has been no public market for the Profit Sharing Certificate of Water Fuel Cell. Application will be made to include all Water Fuel Cell International Business Entities. It is currently estimated that the initial public offering price will be in the range of \$100 (*one hundred dollars*) increments up to \$ 1,000, 000 (*one million dollars*) per profit sharing certificate. See "*Determination of Profit Sharing Price*" for a discussion of the factors considered in determining the Profit Sharing Payment Schedule.

AN INVESTMENT IN THE WATER FUEL CELL PROFIT SHARING CERTIFICATE OFFERED HEREBY INVOLVES A HIGH DEGREE OF RISK. SEE "*RISK FACTORS*".

THESE PROFIT SHARING CERTIFICATES HAVE NOT BEEN APPROVED OR DISAPPROVED BY THE SECURITIES AND EXCHANGE COMMISSION NOR HAS THE COMMISSION PASSED UPON THE ACCURACY OR ADEQUACY OF THIS PROSPECTUS. ANY REPRESENTATION TO THE CONTRARY IS A CRIMINAL OFFENSE.

Information contained herein is subject to completion or amendment. A registration statement relating to these Certificates has been filed with the Securities and Exchange Commission. This prospectus shall not constitute an offer to sell or the solicitation of an offer to buy nor shall there be any sale of these certificates in any State in which such offer, solicitation or sale would be unlawful prior to registration or qualification under the securities laws of any such State.

These Profit Sharing Certificates are offered by Water Fuel Cell. It is expected that delivery of these WFC Profit Sharing Certificates will be made in Grove City, Ohio on or about December , 1988.

The date of this Prospectus is December , 1988

History In The Making

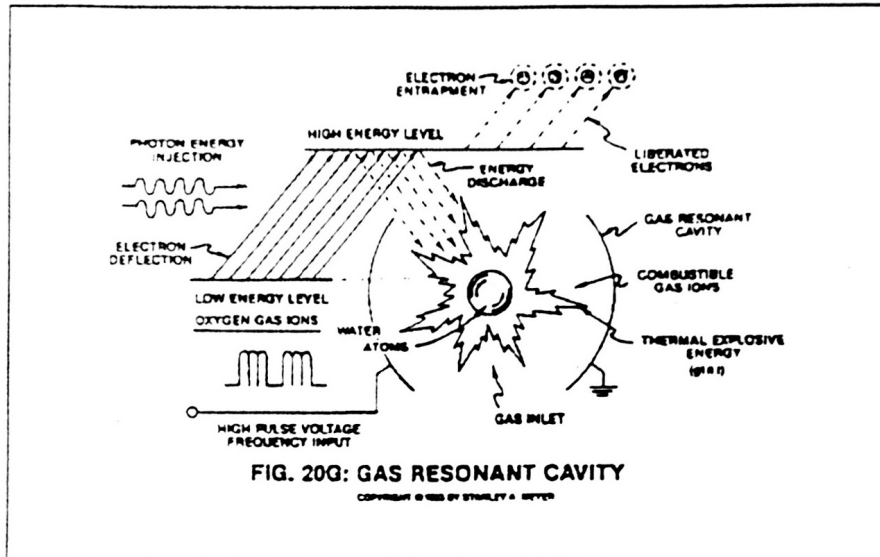

The Hydrogen Fracturing Process (currently in the pre-production stage)

IN CONNECTION WITH THIS CERTIFICATE OFFERING, WATER FUEL CELL MAY OVER-ALLOT OR EFFECT TRANSACTIONS WHICH STABILIZE OR MAINTAIN THE FINANCIAL BASE OF WATER FUEL CELL FOR THE PURPOSE OF INITIATING PROJECT FUNDING AND EXPANDING AND MAINTAINING THE WATER FUEL CELL PRODUCT DEVELOPMENT AND TRADE CENTER. INTERNATIONAL FUNDING WILL BE ACCEPTED UNDER THE PROVISIONS OF SAID CERTIFICATE. MILITARY FUNDING MAY BE EXEMPT FROM SAID CERTIFICATE OFFERING. SUCH FINANCIAL STABILIZATION, IF COMMENCED, MAY BE DISCONTINUED OR ACTIVATED AT ANY TIME.

Water Fuel Cell will furnish its Certificate holders (upon request) with a report containing audited financial statements by its independent public accountants and said financial report will be included with the annual Profit Sharing Payment. (See, Profit Sharing Payment Schedule).

WATER FUEL CELL
International Product Development
and
Trade Center

No dealer, salesperson or other person has been authorized to give any information or to make any representations other than those contained in this Prospectus, and, if given or made, such information or representations must not be relied upon. This Prospectus does not constitute an offer or solicitation by anyone in any jurisdiction in which such offer or solicitation is not authorized, or in which the person making such offer or solicitation is not qualified to do so, or to any person to whom it is unlawful to make such offer or solicitation. Neither the delivery of this Prospectus nor any sale made hereunder shall, under any circumstances, create any implication that there has been no change in the affairs of Water Fuel Cell since the date hereof or that the information herein is correct as of any time subsequent to its date.

TABLE OF CONTENTS

Prospectus Summary.....	Page 5
The Company.....	Page 6
Risk Factors.....	Page 6
The Patents.....	Page 7
Use of Proceeds.....	Page 8
Business.....	Page 8
Profit Sharing Payment Schedule.....	Page 9
WFC Profit Sharing Certificate Agreement.....	Page 10
WFC Dealership Contract Agreement.....	Page 11

Wherever appropriate, transpose and substitute " WFC Profit Sharing Certificate " with " WFC Dealership " when considering purchasing a WFC Dealership.

Stanley A. Meyer
dba Water Fuel Cell
Organizational Flow Chart

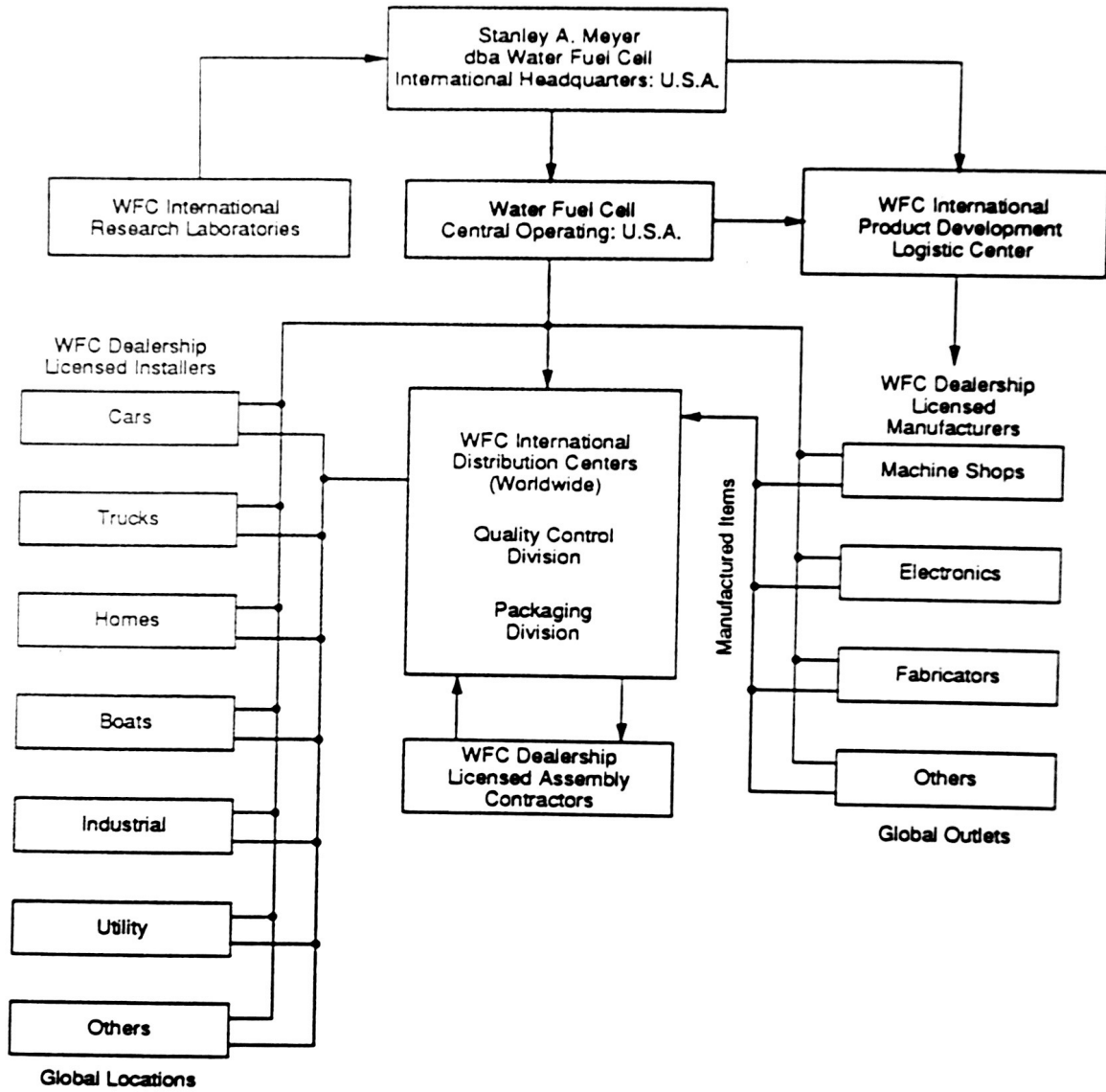

PROSPECTUS SUMMARY

The following summary is qualified in its entirety by the more information and financial statements appearing elsewhere in this prospectus. Unless otherwise indicated, the term " Profit Sharing Certificate " refers to " Certificate of Investment ".

THE COMPANY

Water Fuel Cell is an progressive pioneering research and development company who's expertise are on the leading edge of advance Hydrogen technology...producing hydrogen gas from natural water economically...rendering hydrogen gas safer than natural gas...distributing hydrogen gas without spark-ignition...extracting electrical energy from natural water...releasing " atomic energy " from water under control means at room temperatures...using water as a " new " fuel source.

Water Fuel Cell is, now, establishing The Water Fuel Cell Product Development and Trade Center which will not only have the responsibility of translating the Water Fuel Cell Technology into retrofit energy systems that can be affixed to existing energy consuming devices but will, also, coordinate the sales and distribution of said WFC Energy Systems in the International Market place. (See, *WFC Organizational Flow Chart*).

THE OFFERING

Profit Sharing Certificate.....	unlimited number to be issued
Certificates to be released.....	as cash flow demands
Use of Proceeds.....	For the continued development of the Water Fuel Cell technology and to support the development of the Water Fuel Cell International Product Development and Trade Center. Funds will be used also for development of other related energy products, to fund general corporate (business) purposes while development of the Water Fuel Cell technology is in progress and possibly for the acquisition of related technologies and the protection, if necessary, of patents rights.
Risk Factors.....	An investment in the Profit Sharing Certificate involves a high degree of risk. Prospective investors should carefully review and consider the potential risks set forth under " Risk Factors ".
Payment Schedule.....	Eight percent (8%) of net profit (after taxes) will be distributed to WFC Profit Sharing Certificate Holders in accordance to general accepted accounting procedures. Said payments will not exceed three times (3X) the dollar Value of said WFC Profit Sharing Certificate.

Unless otherwise indicated, Water Fuel Cell reserves the right to restrict the number of Profit Sharing Certificates to be issued to any one person and/or any one investment group ...reserves the right to reject any offer to purchase said Profit Sharing Certificate ...and reserves the right to require said certificate holder to sign a " statements of assets " prior to the purchase of said Certificate.

THE COMPANY

Water Fuel Cell is a progressive pioneering research and development company whose expertise are on the leading edge of advance Hydrogen technology...producing hydrogen gas from natural water economically...rendering hydrogen gas safer than natural gas...distributing hydrogen gas without spark-ignition...extracting electrical energy from natural water...releasing " atomic energy " from natural water under control means at room temperature under environmentally safe conditions...using water as an " New " fuel source. Water Fuel Cell is a proprietorship established since June 1975 By Stanley A. Meyer who has been granted International Patents related to the Hydrogen Energy Technology. See " *The Patents*". Water Fuel Cell maintains its executive offices at 3792 Broadway, Grove City, Ohio 43123, Telephone (614) 871-4173, Fax (614) 871-8075.

Water Fuel Cell is, now, establishing The Water Fuel Cell International Product Development Center and Trade Center which will not only have the responsibility of translating the Water Fuel Cell Technology into retrofit energy systems that can be affixed to existing energy consuming devices but will, also, coordinate the sales and distribution of said WFC Energy Systems in the International Market place while licensing said WFC technology for a given or specific purpose. See " *WFC Organizational Flow Chart* ".

RISK FACTORS

An investment in WFC Profit Sharing Certificate is speculative and involves an unusually high degree of risk. The Profit Sharing Certificate should be purchased only by persons who are sophisticated in financial and business matters and who can afford the risk of losing their entire investment. The following factors, as well as others described elsewhere in this Prospectus, should be carefully considered in evaluating Water Fuel Cell and its business prospects before any decision is made to purchase any Profit Sharing Certificates.

Lack of Products VS Profits

Although scientific experimentations has proven the validity of the Water Fuel Cell technology to secure and obtain both U.S. & Foreign patent rights (see *The Patents*), no product line has been release to date to generate profits since patentability has taken priority over production. Once WFC products enter into the pre-manufacturing stage, EPA approval may be required prior to product distribution. Pre-Market Approval from both the Federal and State government regulatory agencies may be also required to meet certain safety- guide lines such as UL approval. No assurances can be given as to when or whether it will be received. WFC product acceptability should be granted in these areas since hydrogen is an ideal fuel source and its technical-base is in the field of micro electronics.

Reliance on Patents

None of the patents has been tested in the courts. No assurances can be given that if challenged such Patents would prove to be valid and enforceable. The Validity and enforceability of the WFC Patents (see *WFC Technology Base*) is highly significant since WFC patents have already been issued internationally.

THE PATENTS

The following summaries of the issued Patents do not purport to be complete and are subject to, and qualified by, the Patents.

All of the issued Patents are in the name of Stanley A. Meyer and Water Fuel Cell International Product Development and Trade Center will have the responsibility to use the Patents in the development, manufacturing, and sale of the Water Fuel Cell technology in the international market place. The issued Patents derive from a succession of Stanley A. Meyer patent applications deals with different aspects of hydrogen technology. Essentially, there are four distinct topics, each of which was required by the Patent Examiners to be prosecuted as a " process " or " method " application and as an " apparatus " applications, resulting in the issuance of and allowance of eighteen international patent applications with other international patent applications pending allowances.

United States Patents No. 4,613,304 (issued Sept. 23, 1986, and expiring Sept. 23, 2003) titled " Gas Electrical Hydrogen Generator ", No. 3,970,070 (issued July 20, 1976, and expiring July 20, 1993) titled " Solar Heating System ", No. 4,265,224 (issued May 5, 1981, and expiring May 5, 1998) titled " Multi-Stage Solar Storage System ", 4,275,950 (issued Jun 30, 1981, and expiring Jun 30, 1998) " Light-Guide Lens ", No 4,798,661 (issued Jan 17, 1989, and expiring Jan 17, 2006) titled " Gas Generator Voltage Control Circuit ", and Candian Patents No. 1, 228,833 (issued Nov 3, 1987 and expiring Nov. 3, 2004) titled " Gas Electrical Hydrogen Generator ", No. 1,234,774 (issued Apr 5, 1988, and expiring Apr 5, 2005) titled " Hydrogen Generator System ", No. 1,234,773 (issued Apr 5, 1988, and expiring Apr 5, 2005) titled " Resonant Cavity Hydrogen Generator That Operates With a Pulsed Voltage Electrical Potential ", are directed to the " method " and to the " apparatus " aspects of producing hydrogen gas economically .

United States Patents No. 4,421,474 (issued Dec. 20, 1983, and expiring Dec. 2000) titled " Hydrogen Gas Burner ", No. 4,465,455 (issued Aug. 14, 1984, and expiring Aug. 2001) titled " Start up / Shut-Down for a Hydrogen Gas Burner ", No. 4,389,981 (issued Jun 28, 1983, and expiring Jun 28, 2000) titled " Hydrogen Gas Injector System For Internal Combustion Engine ", and Candian Patents No. 1,231,872 (issued Jan 26, 1988, and expiring Jan 26, 2005) titled " Hydrogen Injection System ", No. 1,227,094 (issued Sept. 22, 1987, and expiring Sept. 22, 2004) titled " Hydrogen / Air and Non-Cumbustible Gas Mixing Combustion System ", No. 1,235,669 (issued Apr 26, 1988, and expiring Apr 26, 2005) titled " Controlled Hydrogen Gas Flame ", No. 1,233,379 (issued Mar 1, 1988, and expiring Mar 1, 2005) titled " Hydrogen Gas Injector for Internal Combustion Engine ", are directed to the " method " and to the " apparatus " aspects of rendering hydrogen gas safer than natural gas while allowing the distribution of the hydrogen gas-mixture without spark-ignition.

United States Patent No. 4,613,779 (issued Sep 23, 1986, and expiring Sep 23, 2005) titled " Electrical Pulse Generator ", and Candian Patent No. 1,213,671 (issued Nov 4, 1986, and expiring Nov 4, 2003) titled " Electrical Particle Generator " are directed to the " method " and to the " apparatus " of producing electrical energy for the purpose of releasing hydrogen gas from natural water.

United State Patent No. 4,826,581 (issued May 2, 1989, and expiring May 2, 2006) titled " Controlled Process for the Production of Thermal Energy From Gases and Apparatus Useful Therefore" (The Hydrogen Fracturing Process) is directed to the " method " and to the " apparatus " aspects of releasing " atomic energy " from natural water under control means at room temperature. National Security Clearance has been granted via U.S. Foreign Grant Licenses No. 490199 (issued Sep 23, 1988) and No.490605 (issued Nov. 15, 1988).

USE OF PROCEEDS

For the continued development of the Water Fuel Cell technology and to support the development of the Water Fuel Cell International Product Development and Trade Center. Funds will be used also for development of other related energy products, to fund general corporate (business) purposes while development of the Water Fuel Cell technology is in process and possibly for the acquisition of related technologies and the protection, if necessary, of patents rights.

BUSINESS

Potential Market

Utilizing Hydrogen as a " New " fuel source from natural water will not only help replace the dwindling supply of fossil-fuel needed to maintain and expand the World's Industrial Base; but, also, will help to cancel out the " Greenhouse " and the " Acid Rain " phenomena which directly effects our health and our living environment.

The Water Fuel Cell technology is a retrofit energy technology (add- on equipment) and can be applied to every segment of our energy consuming economy...including but not limited to Industrial, governmental, military, farming, and domestic uses. The Water Fuel Cell technology is, also, suited for the desalinization of sea water, water purification, Oil-Field re-pressurization, Electrical Car power systems, and waste management . Other uses are plausible and applicable to the recycling of materials and substances.

The WFC Tech-base capitalizes on the state-of-the-art of plastic injection molding and micro electronics to promote product-economics by way of mass-production.

General

Water Fuel Cell has completed the first stage of product development by establishing and legalizing its WFC technical-base and, now, is pursuing the implementation and design of pre-manufactured (manufactured prototypes for testing and evaluation purposes) energy systems for the market place while conducting business activities to promote the development of the Water Fuel Cell Product Development and Trade Center. Other business ventures and promotional activities are being considered and acted upon for product exposure and acceptance.

Military projects and related activities remain classify and is not nor will be presented in the scope of this Prospectus.

Marketing Activities To-date

Setting up and developing *WFC Dealership program* (see *WFC Organizational Flow Chart*) to manufacture, fabricate, assembly, distribute, and install WFC products: Formulating WFC Dealership training programs; performing system engineering in relationship to WFC tech-base; meeting with corporations, military, and foreign countries to implement and obtain licensing agreements to promote WFC product-development; and other promotional activities.

Facility Development

The first of several engineering building are on the drawing boards and land acquisition is, now, taking place to establish and expand the WFC Product Development and Trade Center in Washington C.H., Ohio.

Scientists, Engineers, and Technicians are being screened for employment to translate and convert the WFC energy-technology into viable retrofit energy-systems.

Project Priorities

Top priority in reference to WFC system-development will be directed toward the *Transportation, home heating, Grain Dryers* Industries. Military and Governmental projects will coincide with domestic-priorities as demand dictates. Water Purification, Desalination of salt water, and waste management projects will come on-line as project-funding becomes available.

Management Pool

WFC management teams will be expanded and upgraded as co-op development projects come on-line between various segments of industry, governmental, military, and private sectors.

Profit Sharing Payment Schedule

Eight percent (8%) of net profit after taxes will be distributed in accordance to general accepted accounting procedures to WFC Profit Sharing Certificate Holders. Said WFC Profit Sharing payments will not exceed three times (3X) the dollar value of said WFC Profit Sharing Certificate. (See WFC Profit Sharing Certificate attachment).

WFC Dealership Contract Agreement

Contract Date _____	For Official Use Only	Certificate Registration Number DS _____
---------------------	-----------------------	---

Name _____

Address _____

City _____ State _____ Zip _____

Phone: Home () _____; Work () _____

Co-Partner _____

Address _____

City _____ State _____ Zip _____

Phone: Home () _____; Work () _____

Dealership Type _____

Service Area _____

Dealership Value _____ Deposit Am't _____

Balance Due _____ Check No. _____

WFC Dealership Terms Of Assignment

- The undersigned Dealership Purchaser hereby agrees to comply with any and all Water Fuel Cell regulations and policy requirements; and that,
- The undersigned Dealership Purchaser hereby agrees to pay to Water Fuel Cell the above said "Balance Due" at the rate of 5% per sales unit profit until paid; and that,
- The undersigned Dealership Purchaser hereby understands and acknowledges that an investment in the WFC Dealership is speculative and involves an unusually high degree of risk and is being purchased by said Dealership person (s) who is / are sophisticated in financial and business matters and who can afford the risk of losing their entire investment with Water Fuel Cell; and that,
- The undersigned Dealership Purchaser hereby acknowledges receipt of the following attachments: WFC Dealership Sales Manual, Dealership Regulations and Policy Requirements, WFC Profit Sharing Certificate Prospectus, and a copy of this WFC Dealership Contract Agreement; and that,

Notice Of Cancellation

- The undersigned Dealership Purchaser hereby reserves the right to terminate or cancel said WFC Dealership Contract Agreement via certified mail to Water Fuel Cell within seven (7) days from the above said Contract Date.

_____ **Dealership Purchaser Signature**

_____ **WFC Approval Signature**

Water Fuel Cell

Dealership

Regulations and Policy Requirements

Dealership Purchaser is subject to and must comply with any and all Water Fuel Cell regulation and policy requirements; and that,

Dealership Purchase is only an "License" for the "Right-To-Do-Business and that no other tangible and/or non-tangible ownership rights are express and/or implied; and that,

Any and all technical data furnished by Water Fuel Cell to said Dealership Purchaser remains the sole property of Water Fuel Cell and must be returned upon request and shall not be reproduced, copied, nor used as a basis for manufacturing, sales, and/or utilization of said technical data without the express written permission of said Water Fuel Cell; and that,

The above said license "The Right-To-Do-Business" (item 2) is non-transferrable and non-salable to any other person (s) without the express written permission of Water Fuel Cell; and that,

The above said Dealership Purchaser must operate as a fully independent business entity subject to all Federal, State, and local business and tax laws; and that,

The above said Dealership Purchaser must comply with all Water Fuel Cell accounting and audit procedures and requirements; and that,

The above said Dealership Purchaser must use "only" Water Fuel Cell advertising, promotional, and literature material; and that,

The above said Dealership Purchaser must comply to all Water Fuel Cell products codes and installation requirements; and that,

The above said Dealership Purchaser must comply to all sales and manufacturing quota established by Water Fuel Cell per week, per month, and per year; and that,

The above said Dealership Purchaser must comply without exception to all Water Fuel Cell sales/manufacturing pricing-guides; and that,

Failure to comply with any and all Water Fuel Cell requirements and regulations by said Dealership Purchaser shall result in an automatic cancellation of the above said license "The Right-To-Do-Business without deposit refund; and that,

Dealership Deposite (as per Dealership Contract: Agreement) is non-redeemable or non-refundable due to the speculative nature of said Dealership Contract Agreement; and that,

The above said Dealership Purchaser regulation and policy requirements are subject to Water Fuel Cell policy change or revision without written notice to said Dealership Purchaser and said Dealership regulations and requirements are certified under posting via Water Fuel Cell International Headquarters U.S.A..

WFC Dealership Contract Agreement

Contract Date _____	For Official Use Only	Certificate Registration Number DS _____
---------------------	-----------------------	---

Name _____

Address _____

City _____ State _____ Zip _____

Phone: Home () _____; Work () _____

Co-Partner _____

Address _____

City _____ State _____ Zip _____

Phone: Home () _____; Work () _____

Dealership Type _____

Service Area _____

Dealership Value _____ Deposit Am't _____

Balance Due _____ Check No. _____

WFC Dealership Terms Of Assignment

- The undersigned Dealership Purchaser hereby agrees to comply with any and all Water Fuel Cell regulations and policy requirements; and that,
- The undersigned Dealership Purchaser hereby agrees to pay to Water Fuel Cell the above said "Balance Due" at the rate of 5% per sales unit profit until paid; and that,
- The undersigned Dealership Purchaser hereby understands and acknowledges that an investment in the WFC Dealership is speculative and involves an unusually high degree of risk and is being purchased by said Dealership person (s) who is / are sophisticated in financial and business matters and who can afford the risk of losing their entire investment with Water Fuel Cell; and that,
- The undersigned Dealership Purchaser hereby acknowledges receipt of the following attachments: WFC Dealership Sales Manual, Dealership Regulations and Policy Requirements, WFC Profit Sharing Certificate Prospectus, and a copy of this WFC Dealership Contract Agreement; and that,

Notice Of Cancellation

- The undersigned Dealership Purchaser hereby reserves the right to terminate or cancel said WFC Dealership Contract Agreement via certified mail to Water Fuel Cell within seven (7) days from the above said Contract Date.

Dealership Purchaser Signature

WFC Approval Signature

Water Fuel Cell

Dealership

Regulations and Policy Requirements

Dealership Purchaser is subject to and must comply with any and all Water Fuel Cell regulation and policy requirements; and that,

Dealership Purchase is only an "License" for the "Right-To-Do-Business and that no other tangible and/or non-tangible ownership rights are express and/or implied; and that,

Any and all technical data furnished by Water Fuel Cell to said Dealership Purchaser remains the sole property of Water Fuel Cell and must be returned upon request and shall not be reproduced, copied, nor used as a basis for manufacturing, sales, and/or utilization of said technical data without the express written permission of said Water Fuel Cell; and that,

The above said license "The Right-To-Do-Business" (item 2) is non-transferrable and non-salable to any other person (s) without the express written permission of Water Fuel Cell; and that,

The above said Dealership Purchaser must operate as a fully independent business entity subject to all Federal, State, and local business and tax laws; and that,

The above said Dealership Purchaser must comply with all Water Fuel Cell accounting and audit procedures and requirements; and that,

The above said Dealership Purchaser must use "only" Water Fuel Cell advertising, promotional, and literature material; and that,

The above said Dealership Purchaser must comply to all Water Fuel Cell products codes and installation requirements; and that,

The above said Dealership Purchaser must comply to all sales and manufacturing quota established by Water Fuel Cell per week, per month, and per year, and that,

The above said Dealership Purchaser must comply without exception to all Water Fuel Cell sales/manufacturing pricing-guides; and that,

Failure to comply with any and all Water Fuel Cell requirements and regulations by said Dealership Purchaser shall result in an automatic cancellation of the above said license "The Right-To-Do-Business without deposit refund; and that,

Dealership Deposit (as per Dealership Contract Agreement) is non-redeemable or non-refundable due to the speculative nature of said Dealership Contract Agreement; and that,

The above said Dealership Purchaser regulation and policy requirements are subject to Water Fuel Cell policy change or revision without written notice to said Dealership Purchaser and said Dealership regulations and requirements are certified under posting via Water Fuel Cell International Headquarters U.S.A..

INTERNATIONAL WFC PATENT LICENSE AGREEMENT OF ASSIGNMENT
 WATER FUEL CELL, 3792 BROADWAY, GROVE CITY, OHIO 43123, TEL 1-614-871-4173, FAX 1-614-871-8075

CONTRACT DATE	FOR OFFICAL USE ONLY	CERTIFICATE REGISTRATION PL-
---------------	----------------------	---------------------------------

Name _____ Official Status _____

Company _____

Address _____

City _____ State _____ Zip _____

Tel _____ Telex _____ Fax _____

Patent License type _____

Retrofit Description _____ Service Area _____

Patent License Fee: \$ US (_____ .00) _____ Dollars

Deposite \$ (_____ .00) Check _____ Balance \$ (_____ .00) 5% per unit sales until paid

Yearly Maintenance Fee: \$ US (_____ .00) _____

_____ Dollars Per Year _____ Yearly Payment Date

Yearly Royalty Rate: (_____ . _____) % _____ Per Cent of Yearly

Total Gross Income Less Governmental Taxes Payable monthly as per Section (7) as to Section (8)

License Duration of Contract: Life Time Usage of Product Line

WFC Patent License Terms Of Assignment

- The undersigned WFC Patent License Assignee hereby agrees to comply with any and all Water Fuel Cell Regulations and Policy Requirements Of Assignment herein set forth below; and that,
- The undersigned WFC Patent License Assignee hereby understands and acknowledges that an investment in said WFC Patent License Of Assignment is speculative and involves an unusually high degree of risk and is being purchased by said Patent License Assignee (s) who is / are sophisticated in financial and business matters and who can afford the risk of losing their entire investment with Water Fuel Cell; and that,
- The undersigned WFC Patent License Assignee Hereby acknowledges receipt of the following attachments: WFC Dealership Sales Manual; WFC Tech-Brief titled " The Birth of New Technology "; WFC Patent License Terms Of Assignment Regulations and Policy Requirements; WFC Profit Sharing Certificate Prospectus; and a copy of this WFC Patent License Agreement Of Assignment; and that,

Notice Of Cancellation

- The undersigned WFC Patent License Assignee hereby reserves the right to terminate or Cancel said WFC Patent License Agreement of Assignment via Certified Mail to Water Fuel Cell within seven (7) days from the above said Contract Date.

WFC Patent License Assignee

WFC Approval Signature

International
WFC Patent License Agreement
of Assignment
Regulations And Policy Requirements

- 1) WFC Patent License Assignee is subject to and must comply with any and all Water Fuel Cell Regulations And Policy Requirements as herein set forth; and that,
- 2) WFC Patent License Agreement Of Assignment is only a "License" for the Right -To-Do-Business to make, sell and lease, the subject matter embodied in said WFC listing titled "Patent Granted To Date" and any reissue thereof, as herein "no" sublicensing and/or manufacture "use" is granted without the express written permission of said Water Fuel Cell; and that,
- 3) Any and all technical data furnished by Water Fuel Cell to said WFC Patent License Assignee remains the sole property of Water Fuel Cell and must be returned upon request and shall not be reproduced, copied, nor used as a basis for manufacturing, sale and/or utilization of said technical data without express written permission of said Water Fuel Cell; and that,
- 4) The above said License "The Right-To-Do-Business" (items 2) is non-transferrable and non-salable to any other person (s) without express written permission of said Water Fuel Cell; and that,
- 5) WFC Patent License Assignee recognizes the validity of said WFC technology of inventions without legal contest of merit of patent expression (s); and that,
- 6) WFC Patent License Assignee hereby agrees to place said WFC technology of Inventions Patent Numbers and WFC Logo on all articles manufactured and sold, leased, or used under said WFC Patent License Agreement; and that,
- 7) WFC Patent License Assignee hereby agrees to pay Water Fuel Cell said Royalty Fee computed on total gross income less Governmental Taxes without "discount of sales" of each "Product Line" utilizing said WFC technology of inventions, as herein said Royalty fee payments continues as to the life-time usage of said Product-lines; and that,
- 8) WFC Patent License Assignee hereby agrees to provide to said Water Fuel Cell a true and correct accounting of all articles sold, leased, or used hereunder, and to render a full and complete statement of the same within fifteen (15) days after the end of each and every month, setting forth the quantities and gross sales price of the articles sold, leased, or used during the preceding month and simultaneously to make such payment as is due in accordance with item seven (7) of this agreement; and that,
- 9) Water Fuel Cell or his duly authorized representative shall have the right to examine WFC Patent License Assignee account books in regard to the subject matter of this agreement at all reasonable times; and that,
- 10) Standard Of Living Clause... The Minimum Maintenance Fee to be paid to Water Fuel Cell by WFC Patent License Assignee during the life-time of this License shall be increased by seven percent (7 %) compounded on the balance brought forward each year there after until the seventeenth year is reach, at which time, the resultant tabulated balance remains the same each year thereafter; and that,
- 11) Jointly, WFC Patent License Assignee and Water Fuel Cell herein agree that any improvement made in the WFC

- technology of inventions is/are provided to each other at no cost as though they had been included in this license when said license was made and entered into; and that,
- 12) WFC Patent License Assignee herein agree to supply said manufactured units to said Water Fuel Cell (WFC) Dealership Business Entities worldwide at fair market value based on manufacture invoice, as herein said Water Fuel Cell determining shipping quotes per week, per month, and per year, as herein said Water Fuel Cell specifying shipment location of delivery, as herein said WFC Patent License Assignee being allowed to distribute other said manufactured units as so specified under section titled "Service Area" in accordance to section (15); and that,
- 13) WFC Patent License Assignee herein agrees to pay said Water Fuel Cell for any and all technical services rendered to said WFC Patent License Assignee, as herein said payment to be made no later than 30 days from date of invoice (s), as herein travel and accommodation expenses are included in advance payment prior to time of travel should such traveling expenses occur (s), as herein included any other expenses incurred in doing business with said WFC Patent License Assignee; and that,
- 14) WFC Patent License Assignee must operate as a fully independent business entity apart from said Water Fuel Cell and not corporate affiliated with any other business entity, as herein said independent business entity subject to and be in compliance with any and all business and tax laws, as herein said business entity is not to go below accounting ratio 1:1 (for every dollar spent equals one dollar profit) at any given time ; and that,
- 15) Wherein, WFC Patent License Assignee guarantees product liability on all said manufactured and supplied unit (s) , as herein said supplied manufactured units only to be retrofitted to "After Market" energy system (s) that are not O.E.M. Equipment; and that,
- 16) Whereas, WFC Patent License Assignee has only the right to sell to Water Fuel Cell Business entities Worldwide and to no other (s) in accordance to Section (12), as herein said leasing units of distribution to be "Leased" in accordance to Section (15) as to Section titled "service Area", as herein Leasing "Price of Sale" to include manufacturing cost of doing business, maintenance, and service charges of invoicing; and that,
- 17) As herein, said WFC Patent License Terms of Agreement is subject to and must be in compliance with any and all other WFC Contractual Terms of Agreement (s) having placed thereto and subscribing signature of Oath of WFC Patent License of Assignee ; and that,
- 18) Failure by WFC Patent License Assignee to comply with any and all WFC Patent License Agreement Of Assignment Regulations and Policy Requirements herein set forth shall result in a automatic cancellation of above said License "The Right-To-Do-Business without deposit, maintenance Fee, Royalty Fees, and/or invoice fees refund, as herein said cost of doing business fees are non-redeemable and/or non-refundable due to the speculative nature of said WFC Patent License Agreement Of Assignment, as herein said manufacturing design and marketing rights of said manufactured unit (s) remains, without legal contest by WFC Patent License Assignee, the sole property of Water Fuel Cell; and that,
- 19) No other legal terms of definition (s) is/are expressed nor implied.

.....

The Birth of New Technology

Water Fuel Cell Technical Brief

Explaining the Electrical Polarization Process on how to use **WATER** as a **new energy source**.

...“the power-yield of water is greater than fossil fuel.”

*Information not to be used
for manufacturing purposes.*

Stanley A. Meyer
Inventor

History In The Making

'24" for U.S. Mailing
Add '1" for Foreign Delivery
Send money order or
certified check payable to
Water Fuel Cell as addressed.

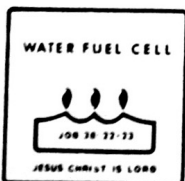

WATER FUEL CELL
INTERNATIONAL HEADQUARTERS: U.S.A.
3792 BROADWAY
GROVE CITY, OHIO 43123
614-871-4173